



GSA prices effective May 30, 2018  
(based on February 6, 2017, commercial price list)  
Published November 2018

## Laboratory Furniture

### Mora™ System

#### **General Services Administration Federal Supply Service Authorized Federal Supply Schedule Price List**

Online access to contract ordering information, terms and conditions, up-to-date pricing, and the option to create an electronic delivery order is available through GSA Advantage!, a menu-driven database system. The Internet address for GSA Advantage! is [www.gsaadvantage.gov](http://www.gsaadvantage.gov). For more information on ordering from Federal Supply Schedules, click on the FSS Schedules button at [www.fss.gsa.gov](http://www.fss.gsa.gov).

FSC Group 66, Part II, Section N  
FSC Classes 6640  
Contract Number: GS-07F-5623R  
Contract Period: February 1, 2015, through January 31, 2020

Herman Miller, Inc.  
855 East Main Avenue  
Zeeland, Michigan 49464  
(616) 654 3000 Phone  
(616) 654 8278 Fax  
[HermanMiller.com/government](http://HermanMiller.com/government)

Business Size: Large



## Contract Information

**1a. Special Item Numbers (SIN)**

566-1: Modular Laboratory Furniture Systems, all product except non-modular Laboratory Tables.

**1b. Lowest Price Model:**

CH800.NH \$20.00

**1c. Not applicable.**

- 2. Maximum Order.** \$400,000 net product value.
- 3. Minimum Order.** \$50 net.
- 4. Geographic Coverage.** 48 contiguous states and District of Columbia. Other geographic locations see box below.
- 5. Production Points.** Zeeland, Michigan, County of Ottawa.
- 6. Pricing.** Prices shown are list. To calculate contract prices, deduct 58.5%.
- 7. Quantity Discounts.** Reference item #6.
- 8. Payment Terms.** Net 30 days.
- 9a. Government Purchase Cards.** ARE accepted below the micropurchase threshold.
- 9b. Government Purchase Cards.** ARE accepted above the micropurchase threshold.
- 10. Foreign Items.** Not applicable.
- 11a. Time of Delivery.** 56 days ARO.
- 11b. Expedited Delivery.** Select items may be available for expedited delivery. Contact Herman Miller, Inc., or local authorized dealer for availability.
- 11c. Overnight and 2-Day Delivery.** Select items may be available for overnight or 2-day delivery. Contact Herman Miller, Inc., or local authorized dealer for availability.
- 11d. Urgent Requirements.** Select items may be available for urgent delivery. Contact Herman Miller, Inc., or local authorized dealer for availability.
- 12. F.O.B. Point.** Destination within the 48 contiguous states and Dist. of Columbia.

**13a. Order Address.** Herman Miller, Inc., Government Customer Care 0161, 855 East Main Avenue, Zeeland, MI 49464.

**13b. Order Procedures.** For supplies and services, the ordering procedures, information on Blanket Purchase Agreements(BPA's), and a sample BPA can be found at the GSA/FSS Schedule home page ([www.fss.gsa.gov/schedules](http://www.fss.gsa.gov/schedules)).

**14. Payment Address.** Herman Miller, Inc., 22764 Network Place, Chicago, IL 60673-1227.

**15. Warranty Provisions.** Herman Miller, Inc., commercial warranty applies.

**16. Export Packing Charges.** Prices supplied on request.

**17. Terms and Conditions of Government Commercial Credit Card Acceptance.** None.

**18. Terms and Conditions of Rental, Maintenance, and Repair.** Not applicable.

**19. Terms and Conditions of Installation.** Installation services shall be negotiated between ordering agency and Herman Miller local authorized dealer.

**20. Terms and Conditions of Repair Parts.** Not applicable.

**20a. Terms and Conditions for Any Other Services.** Services shall be negotiated between ordering agency and Herman Miller local authorized dealer.

**21. List of Service and Distribution Points.** Access Herman Miller web site for current list of participating dealers: [www.HermanMiller.com](http://www.HermanMiller.com).

**22. List of Participating Dealers.** Access Herman Miller web site for current list of participating dealers: [www.HermanMiller.com](http://www.HermanMiller.com).

**23. Preventive Maintenance.** Not applicable.

**24. Special Attributes.** Reconfigurable, renewable.

**25. DUNS Number.** 006012801

**26. Registered in Central Contractor Registration (CCR) Database.** "Herman Miller, Inc."

Herman Miller Miscellaneous Information:

Federal ID Number: 38-0837640

Commercial and Government Entity Code (CAGE): 40636



<b>Introduction</b>	<b>page 2</b>
<b>Mora™ System</b>	<b>3</b>
Wall Attachment	5
Base Cabinets	8
Overhead Cabinets	27
Towers	51
Surfaces	69
Technology Support Solutions	102
Accessories	108
<b>Indices</b>	<b>127</b>
By Name	127
By Number	129
<b>Appendices</b>	
20-Day or Less/Assigned Lead-Time Order Information - Healthcare	
Packaging/Keyed-Alike Information-Mora™ System	
<b>For the latest materials information, refer to the Materials pages on HermanMiller.com.</b>	

# Introduction

## A Note on the Organization of This Book

There are a few signals that will help you understand the organization of this book. Once you know them, you should be able to find your way around easily.

### Like a newspaper, this book is formatted with columns of text and illustrations that run vertically.

Information wraps from one column to the next and continues for as many pages as it needs to.

### Black bars are clues.

A black bar at the top of a page signals the start of information about a product.

This information is divided into two sections, each signaled by a black bar. Product Information includes a description, additional notes, and dimensional drawings. Specification Information, which always begins at the top of a column, includes a series of steps. Each step represents a decision you need to make in order to complete your product number. Steps must be followed sequentially. The number of pages needed to complete information on a product varies; some will be complete in one page; others may fill three or four pages. Just continue going through the steps until you run into the next product, signaled by the black bar at the top of the page.

Black tabs running along the outside edge of the page help you locate what section you are in or what section you want to go to. You can thumb forwards or backwards to find a section; tabs and text appear on both sides of the page.

The additional pages in the back of the book include the appendices and indices. They are signaled by a long black bar running along the outside edge of the page.

### The index is presented two ways.

The first index is in alphabetical order by product name. It can be helpful if you are new to the products and numbering scheme or if you are looking for a type of product, such as work chair or round table.

The second index is by product number. It lists, in alphanumeric order, the base product number, typically a five-digit number.

## General Information

This book is effective May 30, 2018, subject to change without notice. Products may be purchased from authorized Herman Miller dealers who will quote prices upon request. For more information about our products and services or to see a list of dealers, visit [www.HermanMiller.com](http://www.HermanMiller.com).

All prices are list prices. Additional services, such as planning services, design, storage, and installation, are not included and must be added to these prices when the additional services are requested.

Illustrations, specifications, and prices are based on the latest information at the time of publication. The right is reserved to make changes at any time without notice in prices, fabrics, finishes, materials, specifications, and models, and also to discontinue models and finishes.

Dimensions shown in the drawings are engineering drawing dimensions rounded up to the nearest  $\frac{1}{8}$ ". Product is shipped set up or knocked down. Products that include "Shipped knocked down" in the description require some assembly. If this statement does not appear in the description, the product is shipped assembled.

Service problems are normally handled by a Herman Miller authorized dealer. Where this cannot be accomplished on a local level, service problems should be referred to the Customer Care Representative for your region, Herman Miller, Inc., Zeeland, Michigan 49464.

### 20-Day or Less/Assigned Lead-Time Shipments

All products and options in this price book not designated by an Assigned Program icon  will ship in **20 business days or less** after being acknowledged by Herman Miller.

Products and options designated by an  are on the assigned lead-time program and may ship in 20 days, less than 20 days, or more than 20 days from order acknowledgement.

**Wall Attachment**

**Base Cabinets**

**Overhead Cabinets**

**Towers**

**Surfaces**

**Technology Support Solutions**

**Accessories**





# Hanging Cleat

CH100.

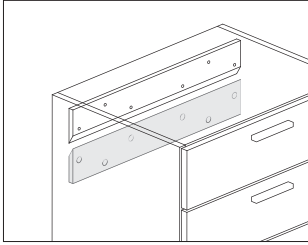

### Product Information

#### Description

This hanging cleat attaches to an architectural wall to support installation of wall-hanging components. It attaches directly to finished 5/8"-thick or thicker drywall using wall anchors specified separately.

#### Notes

Cleat can span multiple cabinets.

Order hanging cleat hardware pack (CH105.) separately.

#### Dimensions

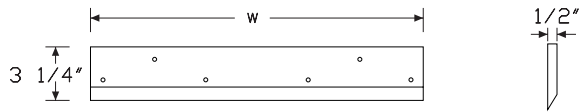

### Specification Information

#### Step 1.

**CH100.**

#### Step 2. Width

<b>15</b>	15" wide
<b>18</b>	18" wide
<b>24</b>	24" wide
<b>30</b>	30" wide
<b>36</b>	36" wide
<b>42</b>	42" wide
<b>48</b>	48" wide
<b>54</b>	54" wide
<b>60</b>	60" wide
<b>63</b>	63" wide
<b>66</b>	66" wide
<b>72</b>	72" wide

#### Prices for Steps 1-2.

<b>CH100. 15</b>	\$29
<b>18</b>	\$29
<b>24</b>	\$31
<b>30</b>	\$35
<b>36</b>	\$40
<b>42</b>	\$43
<b>48</b>	\$45
<b>54</b>	\$55
<b>60</b>	\$58
<b>63</b>	\$62
<b>66</b>	\$64
<b>72</b>	\$66

# Hanging Cleat Hardware Pack

CH105.

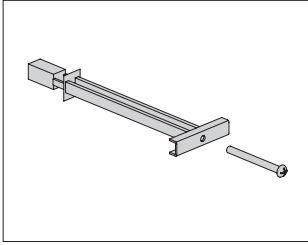

Mora™ Wall Attachment

## Product Information

### Description

This hardware pack is used to attach a hanging cleat to an architectural wall.

### Notes

Order hanging cleat (CH100.) separately.

### Dimensions

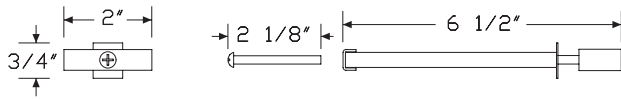

## Specification Information

### Step 1.

**CH105.**

### Step 2. Quantity

**25** 25

**100** 100

### Prices for Steps 1-2.

<b>CH105. 25</b>	\$70
<b>100</b>	\$240

# Ganging Hardware Pack

CH110.

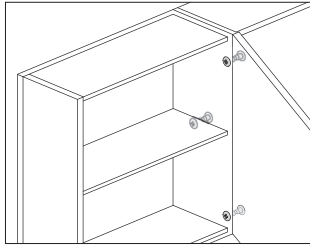

### Product Information

#### Description

This hardware joins 2 side-by-side cabinets and eliminates gaps. 3 fasteners are recommended for each set of cabinet connections.

#### Dimensions

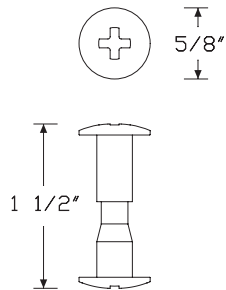

### Specification Information

#### Step 1.

**CH110.**

#### Step 2. Quantity

<b>12</b>	12
<b>50</b>	50

#### Prices for Steps 1-2.

<b>CH110. 12</b>	\$32
<b>50</b>	\$75

Mora™ Wall Attachment

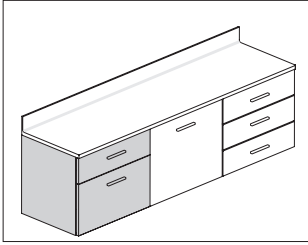

Mora™ Base Cabinets

**Product Information**

**Description**

These cases attach to a hanging cleat to provide storage below a work surface and have drawers with full-extension ball-bearing slides. Cases come in several widths and storage configurations. Finish applies throughout.

**Notes**

Order the following products separately:

- Hanging cleat (CH100.)
- Work surface
- Ganging hardware pack (CH110.)

Lock options lock top drawer only.

For keyed-alike locks, order lock plugs separately.

Case height is 20".

**Dimensions**



← w →

← 18" →

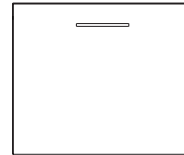

↑ 20 ↓

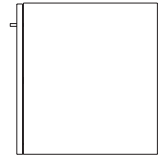

FM



PC

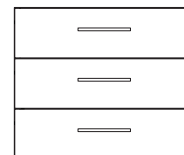
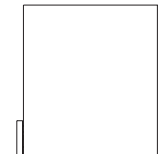

SD

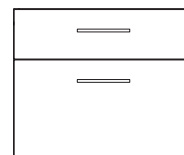
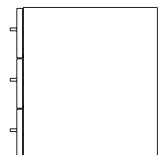

SM

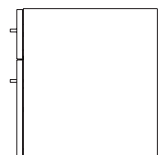

# Wall Mounted Drawer Cases

continued

Mora™ Base Cabinets

## Specification Information

Step 1.

**CH200.**

### Step 2. Width

<b>18</b>	18" wide	+\$871
<b>24</b>	24" wide	+\$936

### Step 3. Depth

<b>19</b>	19" deep	+\$0
-----------	----------	------

### Step 4. Storage Options

*For 18" wide (18)*

<b>SM</b>	individual drawer fronts, 1 small drawer and 1 large drawer	+\$0
<b>SD</b>	individual drawer fronts, 3 small drawers	+\$140
<b>FM</b>	full drawer front, 1 small drawer and 1 large drawer	+\$0

*For 24" wide (24)*

<b>SM</b>	individual drawer fronts, 1 small drawer and 1 large drawer	+\$0
<b>SD</b>	individual drawer fronts, 3 small drawers	+\$140
<b>FM</b>	full drawer front, 1 small drawer and 1 large drawer	+\$0
<b>PC</b>	printer cabinet with pull-out shelf	+\$35

### Step 5. Location in Run (for back-notching)

<b>M</b>	middle of run	+\$0
<b>L</b>	left finished end	+\$0
<b>R</b>	right finished end	+\$0
<b>S</b>	standalone (no notching)	+\$0

### Step 6. Lock Option

*For individual drawer fronts, 1 small drawer and 1 large drawer (SM), individual drawer fronts, 3 small drawers (SD), or full drawer front, 1 small drawer and 1 large drawer (FM)*

<b>NL</b>	no lock	+\$0
<b>KA</b>	keyed lock, keyed alike	+\$60
<b>KC</b>	keyed lock, keyed differently, chrome	+\$60
<b>KD</b>	keyed lock, keyed differently, black	+\$60
<b>KP</b>	keyless lock	+\$275

*For printer cabinet with pull-out shelf (PC)*

<b>NL</b>	no lock	+\$0
-----------	---------	------

### Step 7. Pull Type

*For individual drawer fronts, 1 small drawer and 1 large drawer (SM), individual drawer fronts, 3 small drawers (SD), or full drawer front, 1 small drawer and 1 large drawer (FM)*

<b>A</b>	arc pull	+\$24
<b>K</b>	bar pull	+\$24
<b>T</b>	tab pull	+\$56
<b>P</b>	profile pull	+\$56
<b>C</b>	curved pull	+\$50
<b>N</b>	no pull	+\$0

*For printer cabinet with pull-out shelf (PC)*

<b>N</b>	no pull	+\$0
----------	---------	------

### Step 8. Case/Front/Side Material

<b>L</b>	low-pressure laminate	+\$0
<b>H</b>	high-pressure laminate	+\$225

### Step 9. Grain Direction

<b>HRG</b>	horizontal grain	+\$0
<b>VTG</b>	vertical grain	+\$0

# Wall Mounted Drawer Cases

continued

Mora™ Base Cabinets

## Step 10. Finish

### For low-pressure laminate (L)

<b>76</b>	light brown walnut	+\$0
<b>8Q</b>	folkstone grey	+\$0
<b>91</b>	white	+\$0
<b>98</b>	studio white	+\$0
<b>CL</b>	cool grey neutral	+\$0
<b>HM</b>	natural maple	+\$0
<b>HP</b>	light anigre	+\$0
<b>HX</b>	aged cherry	+\$0
<b>HY</b>	walnut on cherry	+\$0
<b>LA</b>	light ash	+\$0
<b>LBA</b>	clear on ash	+\$0
<b>LBB</b>	oak on ash	+\$0
<b>LBC</b>	walnut on ash	+\$0
<b>LBD</b>	dark brown walnut	+\$0
<b>LBE</b>	medium red walnut	+\$0
<b>LBF</b>	neutral twill	+\$0
<b>LBG</b>	sarum twill	+\$0
<b>LBH</b>	earthen twill	+\$0
<b>LBJ</b>	graphite twill	+\$0
<b>LBK</b>	pewter mesh	+\$0
<b>LBL</b>	steel mesh	+\$0
<b>LBM</b>	crisp linen	+\$0
<b>LBN</b>	classic linen	+\$0
<b>LBP</b>	casual linen	+\$0
<b>LBQ</b>	white twill	+\$0
<b>LBR</b>	phantom ecru	+\$0
<b>LBS</b>	phantom cocoa	+\$0
<b>LBU</b>	medium matte walnut	+\$0
<b>LBV</b>	warm grey teak	+\$0
<b>LU</b>	soft white	+\$0
<b>WL</b>	sandstone	+\$0
<b>WN</b>	warm grey neutral	+\$0

### For high-pressure laminate (H)

<b>76</b>	light brown walnut	+\$0
<b>8Q</b>	folkstone grey	+\$0
<b>91</b>	white	+\$0
<b>98</b>	studio white	+\$0
<b>CL</b>	cool grey neutral	+\$0
<b>HF</b>	inner tone light	+\$0
<b>HM</b>	natural maple	+\$0
<b>HP</b>	light anigre	+\$0
<b>HT</b>	inner tone	+\$0
<b>HX</b>	aged cherry	+\$0

<b>HY</b>	walnut on cherry	+\$0
<b>LA</b>	light ash	+\$0
<b>LBA</b>	clear on ash	+\$0
<b>LBB</b>	oak on ash	+\$0
<b>LBC</b>	walnut on ash	+\$0
<b>LBD</b>	dark brown walnut	+\$0
<b>LBE</b>	medium red walnut	+\$0
<b>LBF</b>	neutral twill	+\$0
<b>LBG</b>	sarum twill	+\$0
<b>LBH</b>	earthen twill	+\$0
<b>LBJ</b>	graphite twill	+\$0
<b>LBK</b>	pewter mesh	+\$0
<b>LBL</b>	steel mesh	+\$0
<b>LBM</b>	crisp linen	+\$0
<b>LBN</b>	classic linen	+\$0
<b>LBP</b>	casual linen	+\$0
<b>LBQ</b>	white twill	+\$0
<b>LBR</b>	phantom ecru	+\$0
<b>LBS</b>	phantom cocoa	+\$0
<b>LBU</b>	medium matte walnut	+\$0
<b>LBV</b>	warm grey teak	+\$0
<b>LM</b>	mahogany	+\$0
<b>LT</b>	light tone	+\$0
<b>LU</b>	soft white	+\$0
<b>MT</b>	medium tone	+\$0
<b>OG</b>	honey maple	+\$0
<b>WL</b>	sandstone	+\$0
<b>WN</b>	warm grey neutral	+\$0

## Step 11. Pull Finish

### For no pull (N)

<b>NN</b>	none	+\$0
-----------	------	------

### For arc pull (A), tab pull (T), profile pull (P), or curved pull (C)

<b>STD</b>	standard finish	+\$0
------------	-----------------	------

### For bar pull (K)

<b>98</b>	studio white	+\$0
<b>8Q</b>	folkstone grey	+\$0
<b>91</b>	white	+\$0
<b>G1</b>	graphite	+\$0
<b>CN</b>	metallic champagne	+\$0
<b>MS</b>	metallic silver	+\$0

# Wall Mounted Door Case

CH210.

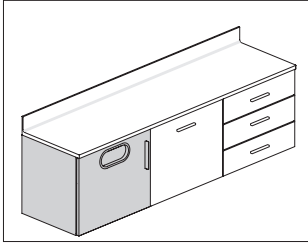

### Product Information

#### Description

These cases attach to a hanging cleat to provide storage below a work surface, trash solutions, or act as sink cabinets. The trash cabinet accommodates a 7-gallon waste bin. Finish applies throughout.

#### Notes

When specifying full door with trash opening (DT), waste bin not included. See Planning Guide for recommendations.

Order work surface or work surface with sink separately.

When using cabinet as a sink cabinet, a fixed panel front option is recommended to hide plumbing.

Full door with trash opening (DT) storage option cannot be used as a sink cabinet.

All storage options have adjustable shelf.

Case height is 20".

Order the following products separately:

- Hanging cleat (CH100.)
- Ganging hardware (CH110.)

### Dimensions



18,24"



20"

FD

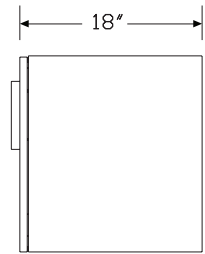

18"

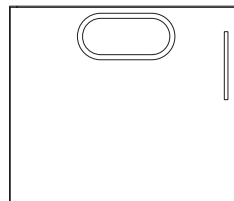

DT

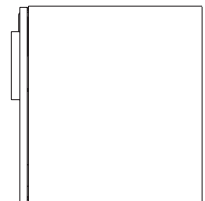

FP

30,36"

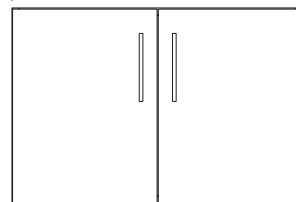

DD

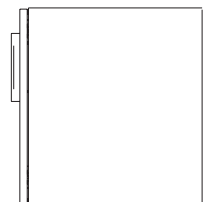

Mora™ Base Cabinets

# Wall Mounted Door Case *continued*

Mora™ Base Cabinets

Specification Information		
Step 1.		
<b>CH210.</b>		
Step 2. Width		
<b>18</b>	18" wide	+\$649
<b>24</b>	24" wide	+\$691
<b>30</b>	30" wide	+\$776
<b>36</b>	36" wide	+\$816
Step 3. Depth		
<b>19</b>	19" deep	+\$0
Step 4. Storage Options		
<i>For 18" wide (18) or 24" wide (24)</i>		
<b>FD</b>	full door	+\$0
<b>DT</b>	full door with trash opening	+\$35
<b>FP</b>	removable panel front	+\$20
<i>For 30" wide (30) or 36" wide (36)</i>		
<b>DD</b>	double doors	+\$0
Step 5. Location in Run (for back-notching)		
<b>M</b>	middle of run	+\$0
<b>L</b>	left finished end	+\$0
<b>R</b>	right finished end	+\$0
<b>S</b>	standalone (no notching)	+\$0
Step 6. Door Hinge Location		
<i>For full door (FD) or full door with trash opening (DT)</i>		
<b>L</b>	left	+\$0
<b>R</b>	right	+\$0
<i>For removable panel front (FP)</i>		
<b>N</b>	no hinge	+\$0
<i>For double doors (DD)</i>		
<b>B</b>	left and right	+\$0

Step 7. Lock Option		
<i>For double doors (DD) or full door (FD)</i>		
<b>NL</b>	no lock	+\$0
<b>KA</b>	keyed lock, keyed alike	+\$60
<b>KC</b>	keyed lock, keyed differently, chrome	+\$60
<b>KD</b>	keyed lock, keyed differently, black	+\$60
<b>KP</b>	keyless lock	+\$275
<i>For full door with trash opening (DT) or removable panel front (FP)</i>		
<b>NL</b>	no lock	+\$0
Step 8. Pull Type		
<i>For double doors (DD), full door (FD), or full door with trash opening (DT)</i>		
<b>A</b>	arc pull	+\$12
<b>K</b>	bar pull	+\$12
<b>T</b>	tab pull	+\$28
<b>P</b>	profile pull	+\$28
<b>C</b>	curved pull	+\$25
<b>N</b>	no pull	+\$0
<i>For removable panel front (FP)</i>		
<b>N</b>	no pull	+\$0
Step 9. Case/Front/Side Material		
<b>L</b>	low-pressure laminate	+\$0
<b>H</b>	high-pressure laminate	+\$225
Step 10. Grain Direction		
<b>HRG</b>	horizontal grain	+\$0
<b>VTG</b>	vertical grain	+\$0



# Wall Mounted Door Case *continued*

## Step 11. Finish

### *For low-pressure laminate (L)*

<b>76</b>	light brown walnut	+\$0
<b>8Q</b>	folkstone grey	+\$0
<b>91</b>	white	+\$0
<b>98</b>	studio white	+\$0
<b>CL</b>	cool grey neutral	+\$0
<b>HM</b>	natural maple	+\$0
<b>HP</b>	light anigre	+\$0
<b>HX</b>	aged cherry	+\$0
<b>HY</b>	walnut on cherry	+\$0
<b>LA</b>	light ash	+\$0
<b>LBA</b>	clear on ash	+\$0
<b>LBB</b>	oak on ash	+\$0
<b>LBC</b>	walnut on ash	+\$0
<b>LBD</b>	dark brown walnut	+\$0
<b>LBE</b>	medium red walnut	+\$0
<b>LBF</b>	neutral twill	+\$0
<b>LBG</b>	sarum twill	+\$0
<b>LBH</b>	earthen twill	+\$0
<b>LBJ</b>	graphite twill	+\$0
<b>LBK</b>	pewter mesh	+\$0
<b>LBL</b>	steel mesh	+\$0
<b>LBM</b>	crisp linen	+\$0
<b>LBN</b>	classic linen	+\$0
<b>LBP</b>	casual linen	+\$0
<b>LBQ</b>	white twill	+\$0
<b>LBR</b>	phantom ecru	+\$0
<b>LBS</b>	phantom cocoa	+\$0
<b>LBU</b>	medium matte walnut	+\$0
<b>LBV</b>	warm grey teak	+\$0
<b>LU</b>	soft white	+\$0
<b>WL</b>	sandstone	+\$0
<b>WN</b>	warm grey neutral	+\$0

### *For high-pressure laminate (H)*

<b>76</b>	light brown walnut	+\$0
<b>8Q</b>	folkstone grey	+\$0
<b>91</b>	white	+\$0
<b>98</b>	studio white	+\$0
<b>CL</b>	cool grey neutral	+\$0
<b>HF</b>	inner tone light	+\$0
<b>HM</b>	natural maple	+\$0
<b>HP</b>	light anigre	+\$0
<b>HT</b>	inner tone	+\$0
<b>HX</b>	aged cherry	+\$0

<b>HY</b>	walnut on cherry	+\$0
<b>LA</b>	light ash	+\$0
<b>LBA</b>	clear on ash	+\$0
<b>LBB</b>	oak on ash	+\$0
<b>LBC</b>	walnut on ash	+\$0
<b>LBD</b>	dark brown walnut	+\$0
<b>LBE</b>	medium red walnut	+\$0
<b>LBF</b>	neutral twill	+\$0
<b>LBG</b>	sarum twill	+\$0
<b>LBH</b>	earthen twill	+\$0
<b>LBJ</b>	graphite twill	+\$0
<b>LBK</b>	pewter mesh	+\$0
<b>LBL</b>	steel mesh	+\$0
<b>LBM</b>	crisp linen	+\$0
<b>LBN</b>	classic linen	+\$0
<b>LBP</b>	casual linen	+\$0
<b>LBQ</b>	white twill	+\$0
<b>LBR</b>	phantom ecru	+\$0
<b>LBS</b>	phantom cocoa	+\$0
<b>LBU</b>	medium matte walnut	+\$0
<b>LBV</b>	warm grey teak	+\$0
<b>LM</b>	mahogany	+\$0
<b>LT</b>	light tone	+\$0
<b>LU</b>	soft white	+\$0
<b>MT</b>	medium tone	+\$0
<b>OG</b>	honey maple	+\$0
<b>WL</b>	sandstone	+\$0
<b>WN</b>	warm grey neutral	+\$0

## Step 12. Pull Finish

### *For no pull (N)*

<b>NN</b>	none	+\$0
-----------	------	------

### *For arc pull (A), tab pull (T), profile pull (P), or curved pull (C)*

<b>STD</b>	standard finish	+\$0
------------	-----------------	------

### *For bar pull (K)*

<b>98</b>	studio white	+\$0
<b>8Q</b>	folkstone grey	+\$0
<b>91</b>	white	+\$0
<b>G1</b>	graphite	+\$0
<b>CN</b>	metallic champagne	+\$0
<b>MS</b>	metallic silver	+\$0

Wall Mounted Door Case *continued*

**Mora™ Base Cabinets**

Step 13. Grommet Finish		
<i>For full door with trash opening (DT)</i>		
<b>8Q</b>	folkstone grey	+\$0
<b>91</b>	white	+\$0
<b>CL</b>	cool grey neutral	+\$0
<b>WL</b>	sandstone	+\$0
<b>WN</b>	warm grey neutral	+\$0

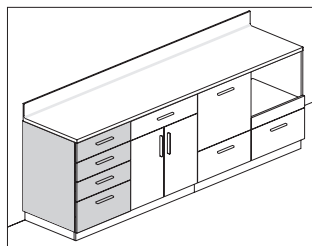

**Product Information**

**Description**

These cases provide storage below a work surface and sit on a plinth base with 1½" adjustable glides. Cases come in several sizes and storage configurations, with or without locks. Finish applies throughout.

**Notes**

Order plinth base (CH250., CH255.) separately.

Order work surface separately.

Lock options lock the top drawer only.

For keyed-alike locks, order lock plugs separately.

For service parts, bottom large drawer has slightly different dimension than middle large drawer.

**Dimensions**

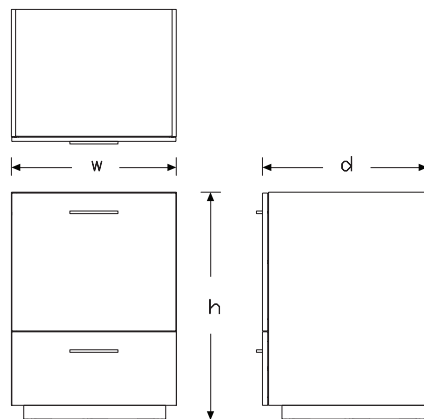

FM

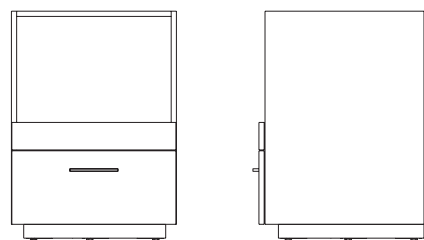

PC

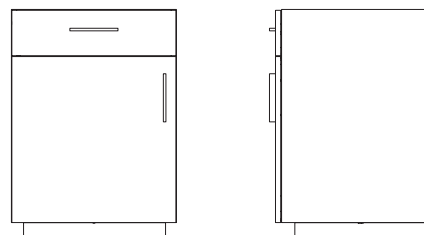

SS

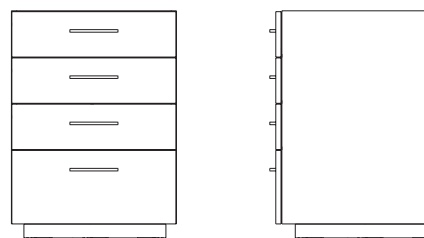

SD

To-The-Floor Drawer Cases *continued*

Mora™ Base Cabinets

Specification Information		
Step 1.		
<b>CH220.</b>		
Step 2. Height		
<b>34</b>	34" high	+\$1330
<b>36</b>	36" high	+\$1345
Step 3. Width		
<b>18</b>	18" wide	+\$0
<b>24</b>	24" wide	+\$30
<b>30</b>	30" wide	+\$100
<b>36</b>	36" wide	+\$0
Step 4. Depth		
<b>19</b>	19" deep	+\$0
<b>24</b>	24" deep	+\$30
<b>30</b>	30" deep	+\$450
Step 5. Storage Options		
<i>For 18" wide (18)</i>		
<b>SD</b>	individual drawer fronts, 3 small drawers, 1 large drawer	+\$0
<b>FM</b>	full drawer front, 1 small drawer, 2 large drawers	-\$145
<b>SS</b>	door and small drawer with shelf	-\$300
<i>For 24" wide (24)</i>		
<b>SD</b>	individual drawer fronts, 3 small drawers, 1 large drawer	+\$0
<b>FM</b>	full drawer front, 1 small drawer, 2 large drawers	-\$135
<b>SS</b>	door and small drawer with shelf	-\$285
<b>PC</b>	printer cabinet with pull-out shelf	+\$0
<i>For 30" wide (30)</i>		
<b>SD</b>	individual drawer fronts, 3 small drawers, 1 large drawer	+\$0
<b>FM</b>	full drawer front, 1 small drawer, 2 large drawers	-\$125
<b>DR</b>	double doors with drawer and shelf	-\$200
<i>For 36" wide (36)</i>		
<b>DR</b>	double doors with drawer and shelf	-\$90
Step 6. Door Hinge Location		
<b>L</b>	left	+\$0
<b>R</b>	right	+\$0

Step 7. Lock Option		
<i>For double doors with drawer and shelf (DR), individual drawer fronts, 3 small drawers, 1 large drawer (SD), full drawer front, 1 small drawer, 2 large drawers (FM), or door and small drawer with shelf (SS)</i>		
<b>NL</b>	no lock	+\$0
<b>KA</b>	keyed lock, keyed alike	+\$60
<b>KC</b>	keyed lock, keyed differently, chrome	+\$60
<b>KD</b>	keyed lock, keyed differently, black	+\$60
<b>KP</b>	keyless lock	+\$275
<i>For printer cabinet with pull-out shelf (PC)</i>		
<b>NL</b>	no lock	+\$0
Step 8. Pull Type		
<b>A</b>	arc pull	+\$24
<b>K</b>	bar pull	+\$24
<b>T</b>	tab pull	+\$56
<b>P</b>	profile pull	+\$56
<b>C</b>	curved pull	+\$50
<b>N</b>	no pull	+\$0
Step 9. Case/Front/Side Material		
<b>L</b>	low-pressure laminate	+\$0
<b>H</b>	high-pressure laminate	+\$240
Step 10. Grain Direction		
<b>HRG</b>	horizontal grain	+\$0
<b>VTG</b>	vertical grain	+\$0

# To-The-Floor Drawer Cases *continued*

## Step 11. Finish

### For low-pressure laminate (L)

<b>76</b>	light brown walnut	+\$0
<b>8Q</b>	folkstone grey	+\$0
<b>91</b>	white	+\$0
<b>98</b>	studio white	+\$0
<b>CL</b>	cool grey neutral	+\$0
<b>HM</b>	natural maple	+\$0
<b>HP</b>	light anigre	+\$0
<b>HX</b>	aged cherry	+\$0
<b>HY</b>	walnut on cherry	+\$0
<b>LA</b>	light ash	+\$0
<b>LBA</b>	clear on ash	+\$0
<b>LBB</b>	oak on ash	+\$0
<b>LBC</b>	walnut on ash	+\$0
<b>LBD</b>	dark brown walnut	+\$0
<b>LBE</b>	medium red walnut	+\$0
<b>LBF</b>	neutral twill	+\$0
<b>LBG</b>	sarum twill	+\$0
<b>LBH</b>	earthen twill	+\$0
<b>LBJ</b>	graphite twill	+\$0
<b>LBK</b>	pewter mesh	+\$0
<b>LBL</b>	steel mesh	+\$0
<b>LBM</b>	crisp linen	+\$0
<b>LBN</b>	classic linen	+\$0
<b>LBP</b>	casual linen	+\$0
<b>LBQ</b>	white twill	+\$0
<b>LBR</b>	phantom ecru	+\$0
<b>LBS</b>	phantom cocoa	+\$0
<b>LBU</b>	medium matte walnut	+\$0
<b>LBV</b>	warm grey teak	+\$0
<b>LU</b>	soft white	+\$0
<b>WL</b>	sandstone	+\$0
<b>WN</b>	warm grey neutral	+\$0

### For high-pressure laminate (H)

<b>76</b>	light brown walnut	+\$0
<b>8Q</b>	folkstone grey	+\$0
<b>91</b>	white	+\$0
<b>98</b>	studio white	+\$0
<b>CL</b>	cool grey neutral	+\$0
<b>HF</b>	inner tone light	+\$0
<b>HM</b>	natural maple	+\$0
<b>HP</b>	light anigre	+\$0
<b>HT</b>	inner tone	+\$0
<b>HX</b>	aged cherry	+\$0

<b>HY</b>	walnut on cherry	+\$0
<b>LA</b>	light ash	+\$0
<b>LBA</b>	clear on ash	+\$0
<b>LBB</b>	oak on ash	+\$0
<b>LBC</b>	walnut on ash	+\$0
<b>LBD</b>	dark brown walnut	+\$0
<b>LBE</b>	medium red walnut	+\$0
<b>LBF</b>	neutral twill	+\$0
<b>LBG</b>	sarum twill	+\$0
<b>LBH</b>	earthen twill	+\$0
<b>LBJ</b>	graphite twill	+\$0
<b>LBK</b>	pewter mesh	+\$0
<b>LBL</b>	steel mesh	+\$0
<b>LBM</b>	crisp linen	+\$0
<b>LBN</b>	classic linen	+\$0
<b>LBP</b>	casual linen	+\$0
<b>LBQ</b>	white twill	+\$0
<b>LBR</b>	phantom ecru	+\$0
<b>LBS</b>	phantom cocoa	+\$0
<b>LBU</b>	medium matte walnut	+\$0
<b>LBV</b>	warm grey teak	+\$0
<b>LM</b>	mahogany	+\$0
<b>LT</b>	light tone	+\$0
<b>LU</b>	soft white	+\$0
<b>MT</b>	medium tone	+\$0
<b>OG</b>	honey maple	+\$0
<b>WL</b>	sandstone	+\$0
<b>WN</b>	warm grey neutral	+\$0

## Step 12. Pull Finish

### For no pull (N)

<b>NN</b>	none	+\$0
-----------	------	------

### For arc pull (A), tab pull (T), profile pull (P), or curved pull (C)

<b>STD</b>	standard finish	+\$0
------------	-----------------	------

### For bar pull (K)

<b>8Q</b>	folkstone grey	+\$0
<b>91</b>	white	+\$0
<b>98</b>	studio white	+\$0
<b>CN</b>	metallic champagne	+\$0
<b>G1</b>	graphite	+\$0
<b>MS</b>	metallic silver	+\$0

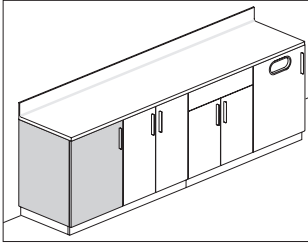

Mora™ Base Cabinets

**Product Information**

**Description**

These cases provide storage below a work surface, trash solutions, or act as sink cabinets. The cases sit on a plinth base with 1½" adjustable glides. The trash cabinet accommodates a 7-gallon waste bin. Finish applies throughout.

**Notes**

When specifying full door with trash cutout (TC), waste bin not included.

See Planning Guide for recommendations.

Order work surface or work surface with sink separately.

Order plinth base (CH250., CH255.) separately.

When using cabinet as a sink cabinet, a fixed panel front option is recommended to hide plumbing.

Door with trash cutout (TC) storage option cannot be used as a sink cabinet.

All storage options have adjustable shelf.

Order ganging hardware (CH110.) separately.

**Dimensions**

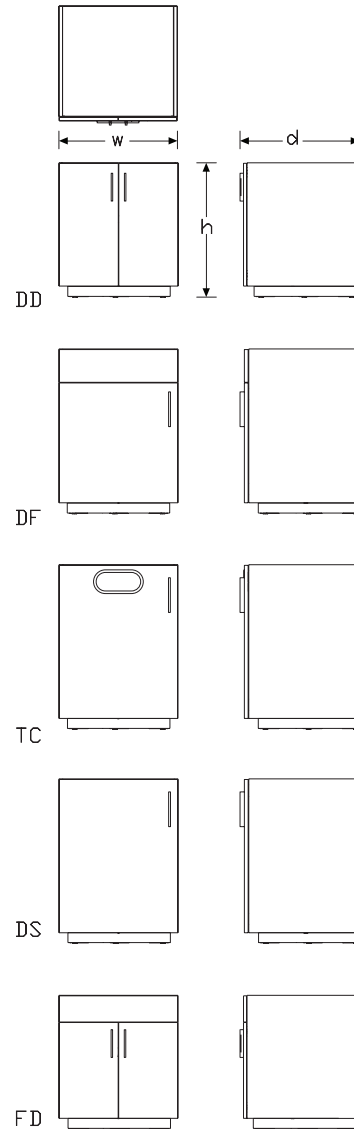

# To-The-Floor Door Cases *continued*

## Specification Information

### Step 1.

**CH230.**

### Step 2. Height

<b>34</b>	34" high	+\$773
<b>36</b>	36" high	+\$783

### Step 3. Width

<b>18</b>	18" wide	+\$0
<b>24</b>	24" wide	+\$35
<b>30</b>	30" wide	+\$285
<b>36</b>	36" wide	+\$325
<b>48</b>	48" wide	+\$415

### Step 4. Depth

<b>19</b>	19" deep	+\$0
<b>24</b>	24" deep	+\$30
<b>30</b>	30" deep	+\$130

### Step 5. Storage Options

*For 18" wide (18) or 24" wide (24)*

<b>DS</b>	full door with shelf	+\$0
<b>TC</b>	door wth trash cutout	+\$30
<b>DF</b>	door with false drawer front and shelf	+\$20

*For 30" wide (30), 36" wide (36), or 48" wide (48)*

<b>DD</b>	double doors with shelf	+\$0
<b>FD</b>	double doors with false drawer front and shelf	+\$20

### Step 6. Door Hinge Location

*For full door with shelf (DS), door wth trash cutout (TC), or door with false drawer front and shelf (DF)*

<b>L</b>	left	+\$0
<b>R</b>	right	+\$0

*For double doors with shelf (DD) or double doors with false drawer front and shelf (FD)*

<b>B</b>	left and right	+\$0
----------	----------------	------

### Step 7. Lock Option

*For double doors with shelf (DD) or full door with shelf (DS)*

<b>NL</b>	no lock	+\$0
<b>KA</b>	keyed lock, keyed alike	+\$60
<b>KC</b>	keyed lock, keyed differently, chrome	+\$60
<b>KD</b>	keyed lock, keyed differently, black	+\$60
<b>KP</b>	keyless lock	+\$275

*For double doors with false drawer front and shelf (FD), door wth trash cutout (TC), or door with false drawer front and shelf (DF)*

<b>NL</b>	no lock	+\$0
-----------	---------	------

### Step 8. Pull Type

<b>A</b>	arc pull	+\$12
<b>K</b>	bar pull	+\$12
<b>T</b>	tab pull	+\$28
<b>P</b>	profile pull	+\$28
<b>C</b>	curved pull	+\$25
<b>N</b>	no pull	+\$0

### Step 9. Case/Front/Side Material

<b>L</b>	low-pressure laminate	+\$0
<b>H</b>	high-pressure laminate	+\$240

### Step 10. Grain Direction

<b>HRG</b>	horizontal grain	+\$0
<b>VTG</b>	vertical grain	+\$0

To-The-Floor Door Cases *continued*

Mora™ Base Cabinets

Step 11. Finish

*For low-pressure laminate (L)*

<b>76</b>	light brown walnut	+\$0
<b>8Q</b>	folkstone grey	+\$0
<b>91</b>	white	+\$0
<b>98</b>	studio white	+\$0
<b>CL</b>	cool grey neutral	+\$0
<b>HM</b>	natural maple	+\$0
<b>HP</b>	light anigre	+\$0
<b>HX</b>	aged cherry	+\$0
<b>HY</b>	walnut on cherry	+\$0
<b>LA</b>	light ash	+\$0
<b>LBA</b>	clear on ash	+\$0
<b>LBB</b>	oak on ash	+\$0
<b>LBC</b>	walnut on ash	+\$0
<b>LBD</b>	dark brown walnut	+\$0
<b>LBE</b>	medium red walnut	+\$0
<b>LBF</b>	neutral twill	+\$0
<b>LBG</b>	sarum twill	+\$0
<b>LBH</b>	earthen twill	+\$0
<b>LBJ</b>	graphite twill	+\$0
<b>LBK</b>	pewter mesh	+\$0
<b>LBL</b>	steel mesh	+\$0
<b>LBM</b>	crisp linen	+\$0
<b>LBN</b>	classic linen	+\$0
<b>LBP</b>	casual linen	+\$0
<b>LBQ</b>	white twill	+\$0
<b>LBR</b>	phantom ecru	+\$0
<b>LBS</b>	phantom cocoa	+\$0
<b>LBU</b>	medium matte walnut	+\$0
<b>LBV</b>	warm grey teak	+\$0
<b>LU</b>	soft white	+\$0
<b>WL</b>	sandstone	+\$0
<b>WN</b>	warm grey neutral	+\$0

*For high-pressure laminate (H)*

<b>76</b>	light brown walnut	+\$0
<b>8Q</b>	folkstone grey	+\$0
<b>91</b>	white	+\$0
<b>98</b>	studio white	+\$0
<b>BU</b>	black umber	+\$0
<b>CL</b>	cool grey neutral	+\$0
<b>HF</b>	inner tone light	+\$0
<b>HM</b>	natural maple	+\$0
<b>HP</b>	light anigre	+\$0
<b>HT</b>	inner tone	+\$0

<b>HX</b>	aged cherry	+\$0
<b>HY</b>	walnut on cherry	+\$0
<b>LA</b>	light ash	+\$0
<b>LBA</b>	clear on ash	+\$0
<b>LBB</b>	oak on ash	+\$0
<b>LBC</b>	walnut on ash	+\$0
<b>LBD</b>	dark brown walnut	+\$0
<b>LBE</b>	medium red walnut	+\$0
<b>LBF</b>	neutral twill	+\$0
<b>LBG</b>	sarum twill	+\$0
<b>LBH</b>	earthen twill	+\$0
<b>LBJ</b>	graphite twill	+\$0
<b>LBK</b>	pewter mesh	+\$0
<b>LBL</b>	steel mesh	+\$0
<b>LBM</b>	crisp linen	+\$0
<b>LBN</b>	classic linen	+\$0
<b>LBP</b>	casual linen	+\$0
<b>LBQ</b>	white twill	+\$0
<b>LBR</b>	phantom ecru	+\$0
<b>LBS</b>	phantom cocoa	+\$0
<b>LBU</b>	medium matte walnut	+\$0
<b>LBV</b>	warm grey teak	+\$0
<b>LM</b>	mahogany	+\$0
<b>LT</b>	light tone	+\$0
<b>LU</b>	soft white	+\$0
<b>MT</b>	medium tone	+\$0
<b>OG</b>	honey maple	+\$0
<b>WL</b>	sandstone	+\$0
<b>WN</b>	warm grey neutral	+\$0

Step 12. Pull Finish

*For no pull (N)*

<b>NN</b>	none	+\$0
-----------	------	------

*For arc pull (A), tab pull (T), profile pull (P), or curved pull (C)*

<b>STD</b>	standard finish	+\$0
------------	-----------------	------

*For bar pull (K)*

<b>8Q</b>	folkstone grey	+\$0
<b>91</b>	white	+\$0
<b>98</b>	studio white	+\$0
<b>CN</b>	metallic champagne	+\$0
<b>G1</b>	graphite	+\$0
<b>MS</b>	metallic silver	+\$0



## To-The-Floor Door Cases *continued*

---

### Step 13. Grommet Finish

*For door wth trash cutout (TC)*

<b>8Q</b>	folkstone grey	+\$0
<b>91</b>	white	+\$0
<b>CL</b>	cool grey neutral	+\$0
<b>WL</b>	sandstone	+\$0
<b>WN</b>	warm grey neutral	+\$0

Plinth Base - Finished

CH250.

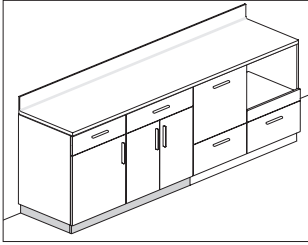

Mora™ Base Cabinets

**Product Information**

**Description**

This HPL plinth base raises to-the-floor cabinets off the floor creating a toe-kick area, is designed to span multiple cabinets, and has 1½" adjustable glides. It is designed to be used without cove molding. Shipped assembled.

**Dimensions**

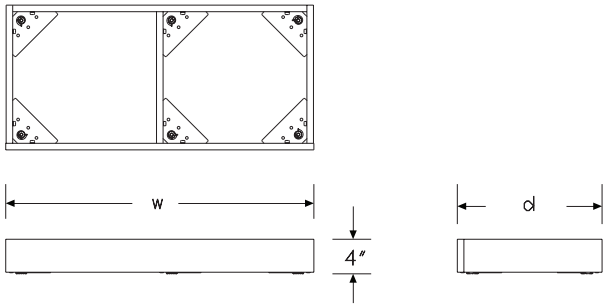

**Specification Information**

**Step 1.**

**CH250.**

**Step 2. Depth**

<b>19</b>	19" deep	+\$250
<b>24</b>	24" deep	+\$275
<b>30</b>	30" deep	+\$325

**Step 3. Width**

<b>15</b>	15" wide	-\$12
<b>18</b>	18" wide	-\$10
<b>24</b>	24" wide	+\$0
<b>30</b>	30" wide	+\$15
<b>36</b>	36" wide	+\$30
<b>42</b>	42" deep	+\$50
<b>48</b>	48" wide	+\$60
<b>54</b>	54" wide	+\$80
<b>60</b>	60" wide	+\$95
<b>63</b>	63" wide	+\$100
<b>66</b>	66" wide	+\$110
<b>72</b>	72" wide	+\$125

**Step 4. Inset (for cabinet)**

<b>B</b>	inset on both (recommended)	+\$0
<b>I</b>	inset on one side	+\$0
<b>C</b>	flush on both (inline)	+\$0

**Step 5. Case/Front/Side Material**

<b>H</b>	high-pressure laminate	+\$0
----------	------------------------	------

**Step 6. Grain Direction**

<b>HRG</b>	horizontal grain	+\$0
------------	------------------	------

**Step 7. Finish**

<b>LBR</b>	phantom ecru	+\$0
<b>LBS</b>	phantom cocoa	+\$0
<b>LBV</b>	warm grey teak	+\$0
<b>1X</b>	vanilla	+\$0
<b>28</b>	canyon	+\$0
<b>29</b>	misted	+\$0
<b>2X</b>	wheat	+\$0
<b>38</b>	twilight	+\$0
<b>39</b>	desert	+\$0
<b>3X</b>	celery	+\$0
<b>4X</b>	coriander	+\$0
<b>5X</b>	chamomile	+\$0

## Plinth Base - Finished *continued*

<b>6X</b>	cinnamon	+\$0
<b>76</b>	light brown walnut	+\$0
<b>7X</b>	cardamom	+\$0
<b>8Q</b>	folkstone grey	+\$0
<b>8X</b>	kale	+\$0
<b>91</b>	white	+\$0
<b>98</b>	studio white	+\$0
<b>BU</b>	black umber	+\$0
<b>CL</b>	cool grey neutral	+\$0
<b>HF</b>	inner tone light	+\$0
<b>HM</b>	natural maple	+\$0
<b>HP</b>	light anigre	+\$0
<b>HT</b>	inner tone	+\$0
<b>HX</b>	aged cherry	+\$0
<b>HY</b>	walnut on cherry	+\$0
<b>LA</b>	light ash	+\$0
<b>LBA</b>	clear on ash	+\$0
<b>LBB</b>	oak on ash	+\$0
<b>LBC</b>	walnut on ash	+\$0
<b>LBD</b>	dark brown walnut	+\$0
<b>LBE</b>	medium red walnut	+\$0
<b>LBF</b>	neutral twill	+\$0
<b>LBG</b>	sarum twill	+\$0
<b>LBH</b>	earthen twill	+\$0
<b>LBJ</b>	graphite twill	+\$0
<b>LBK</b>	pewter mesh	+\$0
<b>LBL</b>	steel mesh	+\$0
<b>LBM</b>	crisp linen	+\$0
<b>LBN</b>	classic linen	+\$0
<b>LBP</b>	casual linen	+\$0
<b>LBQ</b>	white twill	+\$0
<b>LBU</b>	medium matte walnut	+\$0
<b>LG</b>	light grey (discontinuing)	+\$0
<b>LM</b>	mahogany	+\$0
<b>LT</b>	light tone	+\$0
<b>LU</b>	soft white	+\$0
<b>MT</b>	medium tone	+\$0
<b>WL</b>	sandstone	+\$0
<b>WN</b>	warm grey neutral	+\$0
<b>X1</b>	chalk white	+\$0

Plinth Base - Unfinished

CH255.

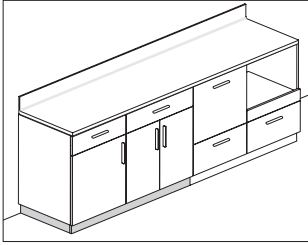

Mora™ Base Cabinets

**Product Information**

**Description**  
 This unfinished plinth base raises to-the-floor cabinets off the floor creating a toe-kick area, is designed to span multiple cabinets, and has 1 1/2" adjustable glides. It is designed to be used without cove molding and has unfinished ends. Shipped assembled.

**Dimensions**

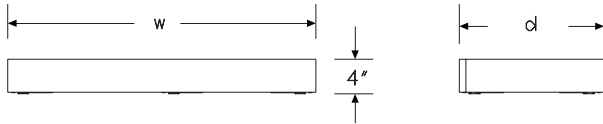
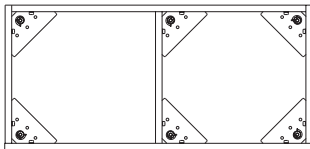

**Specification Information**

**Step 1.**  
**CH255.**

**Step 2. Depth**

<b>19</b>	19" deep	+\$215
<b>24</b>	24" deep	+\$240
<b>30</b>	30" deep	+\$290

**Step 3. Width**

<b>15</b>	15" wide	-\$12
<b>18</b>	18" wide	-\$10
<b>24</b>	24" wide	+\$0
<b>30</b>	30" wide	+\$15
<b>36</b>	36" wide	+\$30
<b>42</b>	42" wide	+\$50
<b>48</b>	48" wide	+\$60
<b>54</b>	54" wide	+\$80
<b>60</b>	60" wide	+\$95
<b>63</b>	63" wide	+\$100
<b>66</b>	66" wide	+\$110
<b>72</b>	72" wide	+\$125

**Step 4. Inset (for cabinet)**

<b>B</b>	inset on both (recommended)	+\$0
<b>C</b>	flush on both (inline)	+\$0
<b>I</b>	inset on one side	+\$0

**Step 5. Finish**

<b>91</b>	white	+\$0
-----------	-------	------

# ADA Sink Enclosure

CH240.

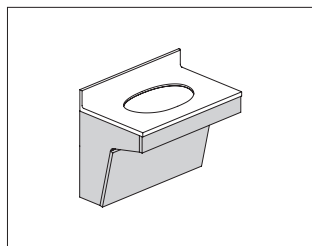

### Product Information

#### Description

This sink enclosure hangs from an architectural wall. Enclosure has a removable front panel to allow access to plumbing.

#### Notes

Order Corian® worksurface with ADA sink (CH607.) separately.  
Faucet must be field supplied.

#### Dimensions

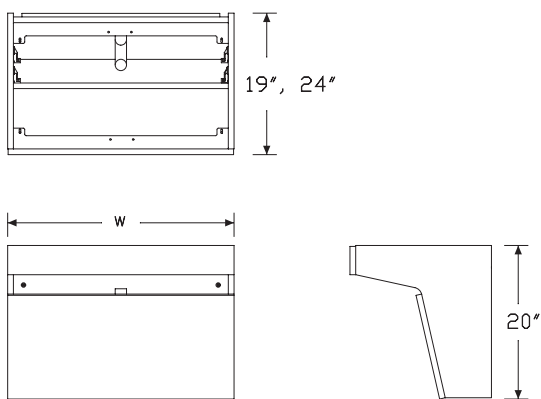

### Specification Information

#### Step 1.

**CH240.**

#### Step 2. Depth

<b>19</b>	19" deep	+\$900
<b>24</b>	24" deep	+\$950

#### Step 3. Width

<b>24</b>	24" wide	-\$15
<b>30</b>	30" wide	+\$0

#### Step 4. Height

<b>STD</b>	standard	+\$0
------------	----------	------

#### Step 5. Surface Material

<b>H</b>	high-pressure laminate	+\$170
<b>L</b>	low-pressure laminate	+\$0

#### Step 6. Grain Direction

<b>HRG</b>	horizontal grain	+\$0
<b>VTG</b>	vertical grain	+\$0

Mora™ Base Cabinets

Step 7. Finish

*For low-pressure laminate (L)*

<b>76</b>	light brown walnut	+\$0
<b>8Q</b>	folkstone grey	+\$0
<b>91</b>	white	+\$0
<b>98</b>	studio white	+\$0
<b>CL</b>	cool grey neutral	+\$0
<b>HM</b>	natural maple	+\$0
<b>HP</b>	light anigre	+\$0
<b>HX</b>	aged cherry	+\$0
<b>HY</b>	walnut on cherry	+\$0
<b>LA</b>	light ash	+\$0
<b>LBA</b>	clear on ash	+\$0
<b>LBB</b>	oak on ash	+\$0
<b>LBC</b>	walnut on ash	+\$0
<b>LBD</b>	dark brown walnut	+\$0
<b>LBE</b>	medium red walnut	+\$0
<b>LBF</b>	neutral twill	+\$0
<b>LBG</b>	sarum twill	+\$0
<b>LBH</b>	earthen twill	+\$0
<b>LBJ</b>	graphite twill	+\$0
<b>LBK</b>	pewter mesh	+\$0
<b>LBL</b>	steel mesh	+\$0
<b>LBM</b>	crisp linen	+\$0
<b>LBN</b>	classic linen	+\$0
<b>LBP</b>	casual linen	+\$0
<b>LBQ</b>	white twill	+\$0
<b>LBU</b>	medium matte walnut	+\$0
<b>LU</b>	soft white	+\$0
<b>WL</b>	sandstone	+\$0
<b>WN</b>	warm grey neutral	+\$0

*For high-pressure laminate (H)*

<b>76</b>	light brown walnut	+\$0
<b>8Q</b>	folkstone grey	+\$0
<b>91</b>	white	+\$0
<b>98</b>	studio white	+\$0
<b>CL</b>	cool grey neutral	+\$0
<b>HF</b>	inner tone light	+\$0
<b>HM</b>	natural maple	+\$0
<b>HP</b>	light anigre	+\$0
<b>HT</b>	inner tone	+\$0
<b>HX</b>	aged cherry	+\$0
<b>HY</b>	walnut on cherry	+\$0
<b>LA</b>	light ash	+\$0
<b>LBA</b>	clear on ash	+\$0
<b>LBB</b>	oak on ash	+\$0
<b>LBC</b>	walnut on ash	+\$0
<b>LBD</b>	dark brown walnut	+\$0
<b>LBE</b>	medium red walnut	+\$0
<b>LBF</b>	neutral twill	+\$0
<b>LBG</b>	sarum twill	+\$0
<b>LBH</b>	earthen twill	+\$0
<b>LBJ</b>	graphite twill	+\$0
<b>LBK</b>	pewter mesh	+\$0
<b>LBL</b>	steel mesh	+\$0
<b>LBM</b>	crisp linen	+\$0
<b>LBN</b>	classic linen	+\$0
<b>LBP</b>	casual linen	+\$0
<b>LBQ</b>	white twill	+\$0
<b>LBU</b>	medium matte walnut	+\$0
<b>LM</b>	mahogany	+\$0
<b>LT</b>	light tone	+\$0
<b>LU</b>	soft white	+\$0
<b>MT</b>	medium tone	+\$0
<b>WL</b>	sandstone	+\$0
<b>WN</b>	warm grey neutral	+\$0

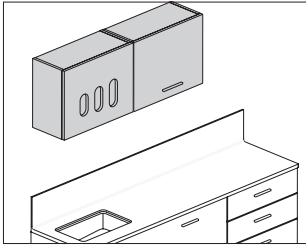

**Product Information**

**Description**

These overhead cabinets attach to an architectural wall with a hanging cleat. They are available in several sizes and storage configurations. All storage options include an adjustable shelf.

**Notes**

- Overhead cabinets wider than 36" have vertical divider.
- When specifying paper towel cabinet (P) or paper towel/glove holder combo cabinet (C), paper towel dispenser is field supplied.
- For keyed-alike locks, order lock plugs separately.
- Order the following products separately:
  - Hanging cleat (CH100.)
  - Ganging hardware (CH110.)

**Dimensions**

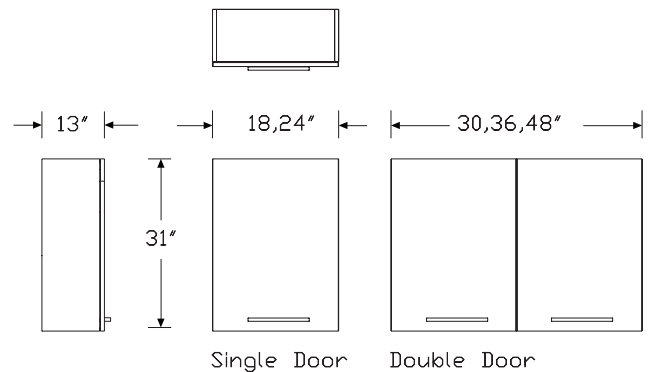
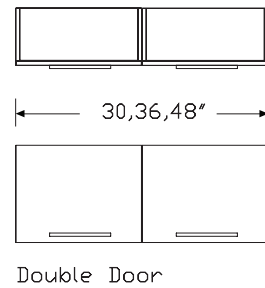
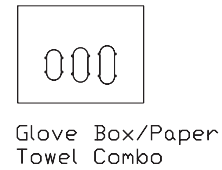
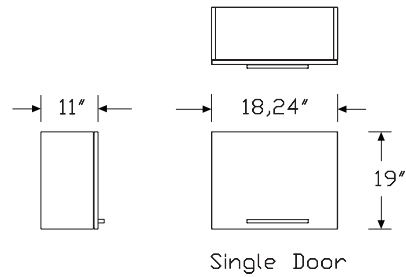

# Overhead Storage *continued*

Mora™ Overhead Cabinets

Specification Information		
Step 1.		
<b>CH300.</b>		
Step 2. Height		
<b>19</b>	19" high	+\$548
<b>31</b>	31" high	+\$653
Step 3. Width		
<b>18</b>	18" wide	+\$0
<b>24</b>	24" wide	+\$30
<b>30</b>	30" wide	+\$130
<b>36</b>	36" wide	+\$170
<b>48</b>	48" wide	+\$300
Step 4. Depth		
<i>For 19" high (19)</i>		
<b>11</b>	11" deep	+\$0
<i>For 31" high (31)</i>		
<b>13</b>	13" deep	+\$0
Step 5. Storage Options		
<i>For 19" high (19) with 18" wide (18) or 24" wide (24)</i>		
<b>S</b>	single door	+\$0
<b>C</b>	paper towel/glove holder combo cabinet	+\$150
<b>P</b>	paper towel cabinet	+\$0
<b>G</b>	glove holder cabinet	+\$150
<i>For 31" high (31) with 18" wide (18) or 24" wide (24)</i>		
<b>S</b>	single door	+\$0
<b>P</b>	paper towel cabinet	+\$0
<i>For 19" high (19) or 31" high (31) with 30" wide (30), 36" wide (36), or 48" wide (48)</i>		
<b>D</b>	double door	+\$0
Step 6. Location in Run		
<b>S</b>	standalone	+\$0
<b>M</b>	middle of run	+\$0
<b>L</b>	left end	+\$0
<b>R</b>	right end	+\$0

Step 7. Door Hinge Location		
<i>For single door (S), paper towel/glove holder combo cabinet (C), paper towel cabinet (P), or glove holder cabinet (G)</i>		
<b>L</b>	left	+\$0
<b>R</b>	right	+\$0
<i>For double door (D)</i>		
<b>S</b>	default	+\$0
Step 8. Lock Option		
<i>For double door (D) or single door (S)</i>		
<b>NL</b>	no lock	+\$0
<b>KA</b>	keyed lock, keyed alike	+\$60
<b>KC</b>	keyed lock, keyed differently, chrome	+\$60
<b>KD</b>	keyed lock, keyed differently, black	+\$60
<b>KP</b>	keyless lock	+\$275
<i>For paper towel/glove holder combo cabinet (C), paper towel cabinet (P), or glove holder cabinet (G)</i>		
<b>NL</b>	no lock	+\$0
Step 9. Pull Type		
<i>For double door (D), single door (S), paper towel cabinet (P), or glove holder cabinet (G)</i>		
<b>A</b>	arc pull	+\$12
<b>K</b>	bar pull	+\$12
<b>T</b>	tab pull	+\$28
<b>P</b>	profile pull	+\$28
<b>C</b>	curved pull	+\$25
<b>N</b>	no pull	+\$0
<i>For paper towel/glove holder combo cabinet (C)</i>		
<b>N</b>	no pull	+\$0
Step 10. Surface Material		
<b>L</b>	low-pressure laminate	+\$0
<b>H</b>	high-pressure laminate	+\$240
Step 11. Grain Direction		
<b>HRG</b>	horizontal grain	+\$0
<b>VTG</b>	vertical grain	+\$0



# Overhead Storage *continued*

**Step 12. Finish**

*For low-pressure laminate (L)*

<b>76</b>	light brown walnut	+\$0
<b>8Q</b>	folkstone grey	+\$0
<b>91</b>	white	+\$0
<b>98</b>	studio white	+\$0
<b>CL</b>	cool grey neutral	+\$0
<b>HM</b>	natural maple	+\$0
<b>HP</b>	light anigre	+\$0
<b>HX</b>	aged cherry	+\$0
<b>HY</b>	walnut on cherry	+\$0
<b>LA</b>	light ash	+\$0
<b>LBA</b>	clear on ash	+\$0
<b>LBR</b>	phantom ecru	+\$0
<b>LBS</b>	phantom cocoa	+\$0
<b>LBU</b>	medium matte walnut	+\$0
<b>LBV</b>	warm grey teak	+\$0
<b>LBB</b>	oak on ash	+\$0
<b>LBC</b>	walnut on ash	+\$0
<b>LBD</b>	dark brown walnut	+\$0
<b>LBE</b>	medium red walnut	+\$0
<b>LBF</b>	neutral twill	+\$0
<b>LBG</b>	sarum twill	+\$0
<b>LBH</b>	earthen twill	+\$0
<b>LBJ</b>	graphite twill	+\$0
<b>LBK</b>	pewter mesh	+\$0
<b>LBL</b>	steel mesh	+\$0
<b>LBM</b>	crisp linen	+\$0
<b>LBN</b>	classic linen	+\$0
<b>LBP</b>	casual linen	+\$0
<b>LBQ</b>	white twill	+\$0
<b>LU</b>	soft white	+\$0
<b>WL</b>	sandstone	+\$0
<b>WN</b>	warm grey neutral	+\$0

*For high-pressure laminate (H)*

<b>76</b>	light brown walnut	+\$0
<b>8Q</b>	folkstone grey	+\$0
<b>91</b>	white	+\$0
<b>98</b>	studio white	+\$0
<b>CL</b>	cool grey neutral	+\$0
<b>HF</b>	inner tone light	+\$0
<b>HM</b>	natural maple	+\$0
<b>HP</b>	light anigre	+\$0
<b>HT</b>	inner tone	+\$0
<b>HX</b>	aged cherry	+\$0

<b>HY</b>	walnut on cherry	+\$0
<b>LA</b>	light ash	+\$0
<b>LBA</b>	clear on ash	+\$0
<b>LBR</b>	phantom ecru	+\$0
<b>LBS</b>	phantom cocoa	+\$0
<b>LBV</b>	warm grey teak	+\$0
<b>LBU</b>	medium matte walnut	+\$0
<b>LBB</b>	oak on ash	+\$0
<b>LBC</b>	walnut on ash	+\$0
<b>LBD</b>	dark brown walnut	+\$0
<b>LBE</b>	medium red walnut	+\$0
<b>LBF</b>	neutral twill	+\$0
<b>LBG</b>	sarum twill	+\$0
<b>LBH</b>	earthen twill	+\$0
<b>LBJ</b>	graphite twill	+\$0
<b>LBK</b>	pewter mesh	+\$0
<b>LBL</b>	steel mesh	+\$0
<b>LBM</b>	crisp linen	+\$0
<b>LBN</b>	classic linen	+\$0
<b>LBP</b>	casual linen	+\$0
<b>LBQ</b>	white twill	+\$0
<b>LM</b>	mahogany	+\$0
<b>LT</b>	light tone	+\$0
<b>LU</b>	soft white	+\$0
<b>MT</b>	medium tone	+\$0
<b>OL</b>	white oak (nonstandard)	+\$0
<b>WL</b>	sandstone	+\$0
<b>WN</b>	warm grey neutral	+\$0

**Step 13. Pull Finish**

*For no pull (N)*

<b>NN</b>	no pull finish	+\$0
-----------	----------------	------

*For arc pull (A), tab pull (T), profile pull (P), or curved pull (C)*

<b>STD</b>	standard finish	+\$0
------------	-----------------	------

*For bar pull (K)*

<b>8Q</b>	folkstone grey	+\$0
<b>91</b>	white	+\$0
<b>98</b>	studio white	+\$0
<b>CN</b>	metallic champagne	+\$0
<b>G1</b>	graphite	+\$0
<b>MS</b>	metallic silver	+\$0

# Overhead Storage *continued*

---

**Step 14. Grommet Finish**

*For paper towel/glove holder combo cabinet (C) or glove holder cabinet (G)*

<b>8Q</b>	folkstone grey	+\$0
<b>91</b>	white	+\$0
<b>CL</b>	cool grey neutral	+\$0
<b>WL</b>	sandstone	+\$0
<b>WN</b>	warm grey neutral	+\$0

**Mora™ Overhead Cabinets**

# Awning Overhead Storage

CH301.

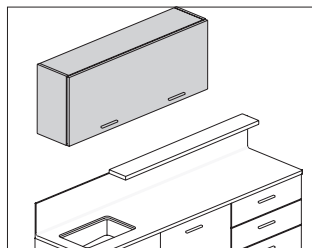

### Product Information

#### Description

These overhead cabinets attach to an architectural wall with a hanging cleat. They are available in several sizes and have a door that is hinged at the top and opens upward. Adjustable shelf included.

#### Notes

Overhead cabinets wider than 36" have vertical divider.

Order the following products separately:

- Hanging cleat (CH100.)
- Ganging hardware (CH110.)

#### Dimensions

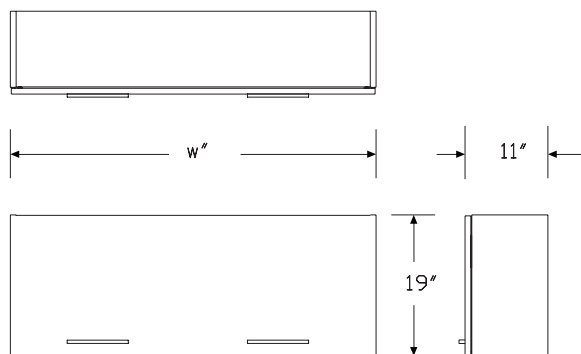

### Specification Information

#### Step 1.

**CH301.**

#### Step 2. Height

**19** 19" high +\$925

#### Step 3. Width

**30** 30" wide +\$0

**36** 36" wide +\$75

**48** 48" wide +\$175

#### Step 4. Depth

**11** 11" deep +\$0

#### Step 5. Storage Options

**A** awning door +\$0

#### Step 6. Location in Run

**S** standalone +\$0

**M** middle of run +\$0

**L** left end +\$0

**R** right end +\$0

#### Step 7. Lock Option

**NL** no lock +\$0

#### Step 8. Pull Type

**A** arc pull +\$12

**K** bar pull +\$12

**T** tab pull +\$28

**P** profile pull +\$28

**C** curved pull +\$25

**N** no pull +\$0

#### Step 9. Surface Material

**L** low-pressure laminate +\$0

**H** high-pressure laminate +\$240

#### Step 10. Grain Direction

**HRG** horizontal grain +\$0

**VTG** vertical grain  +\$0

# Awning Overhead Storage *continued*

Mora™ Overhead Cabinets

## Step 11. Finish

### For low-pressure laminate (L)

<b>76</b>	light brown walnut	+\$0
<b>8Q</b>	folkstone grey	+\$0
<b>91</b>	white	+\$0
<b>98</b>	studio white	+\$0
<b>CL</b>	cool grey neutral	+\$0
<b>HM</b>	natural maple	+\$0
<b>HP</b>	light anigre	+\$0
<b>HX</b>	aged cherry	+\$0
<b>HY</b>	walnut on cherry	+\$0
<b>LA</b>	light ash	+\$0
<b>LBA</b>	clear on ash	+\$0
<b>LBR</b>	phantom ecru	+\$0
<b>LBS</b>	phantom cocoa	+\$0
<b>LBU</b>	medium matte walnut	+\$0
<b>LBV</b>	warm grey teak	+\$0
<b>LBB</b>	oak on ash	+\$0
<b>LBC</b>	walnut on ash	+\$0
<b>LBD</b>	dark brown walnut	+\$0
<b>LBE</b>	medium red walnut	+\$0
<b>LBF</b>	neutral twill	+\$0
<b>LBG</b>	sarum twill	+\$0
<b>LBH</b>	earthen twill	+\$0
<b>LBJ</b>	graphite twill	+\$0
<b>LBK</b>	pewter mesh	+\$0
<b>LBL</b>	steel mesh	+\$0
<b>LBM</b>	crisp linen	+\$0
<b>LBN</b>	classic linen	+\$0
<b>LBP</b>	casual linen	+\$0
<b>LBQ</b>	white twill	+\$0
<b>LU</b>	soft white	+\$0
<b>WL</b>	sandstone	+\$0
<b>WN</b>	warm grey neutral	+\$0

### For high-pressure laminate (H)

<b>76</b>	light brown walnut	+\$0
<b>8Q</b>	folkstone grey	+\$0
<b>91</b>	white	+\$0
<b>98</b>	studio white	+\$0
<b>CL</b>	cool grey neutral	+\$0
<b>HF</b>	inner tone light	+\$0
<b>HM</b>	natural maple	+\$0
<b>HP</b>	light anigre	+\$0
<b>HT</b>	inner tone	+\$0
<b>HX</b>	aged cherry	+\$0

<b>HY</b>	walnut on cherry	+\$0
<b>LA</b>	light ash	+\$0
<b>LBA</b>	clear on ash	+\$0
<b>LBR</b>	phantom ecru	+\$0
<b>LBS</b>	phantom cocoa	+\$0
<b>LBV</b>	warm grey teak	+\$0
<b>LBU</b>	medium matte walnut	+\$0
<b>LBB</b>	oak on ash	+\$0
<b>LBC</b>	walnut on ash	+\$0
<b>LBD</b>	dark brown walnut	+\$0
<b>LBE</b>	medium red walnut	+\$0
<b>LBF</b>	neutral twill	+\$0
<b>LBG</b>	sarum twill	+\$0
<b>LBH</b>	earthen twill	+\$0
<b>LBJ</b>	graphite twill	+\$0
<b>LBK</b>	pewter mesh	+\$0
<b>LBL</b>	steel mesh	+\$0
<b>LBM</b>	crisp linen	+\$0
<b>LBN</b>	classic linen	+\$0
<b>LBP</b>	casual linen	+\$0
<b>LBQ</b>	white twill	+\$0
<b>LM</b>	mahogany	+\$0
<b>LT</b>	light tone	+\$0
<b>LU</b>	soft white	+\$0
<b>MT</b>	medium tone	+\$0
<b>OL</b>	white oak (nonstandard)	+\$0
<b>WL</b>	sandstone	+\$0
<b>WN</b>	warm grey neutral	+\$0

## Step 12. Pull Finish

### For no pull (N)

<b>NN</b>	no pull finish	+\$0
-----------	----------------	------

### For arc pull (A), tab pull (T), profile pull (P), or curved pull (C)

<b>STD</b>	standard finish	+\$0
------------	-----------------	------

### For bar pull (K)

<b>8Q</b>	folkstone grey	+\$0
<b>91</b>	white	+\$0
<b>98</b>	studio white	+\$0
<b>CN</b>	metallic champagne	+\$0
<b>G1</b>	graphite	+\$0
<b>MS</b>	metallic silver	+\$0

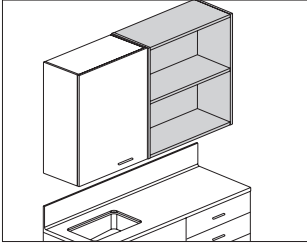

**Product Information**

**Description**

These open-shelf cabinets attach to an architectural wall with a hanging cleat. They are available in several sizes and have an adjustable shelf.

**Notes**

Cabinets wider than 36" have vertical divider.

Order the following products separately:

- Hanging cleat (CH100.)
- Ganging hardware (CH110.)

**Dimensions**

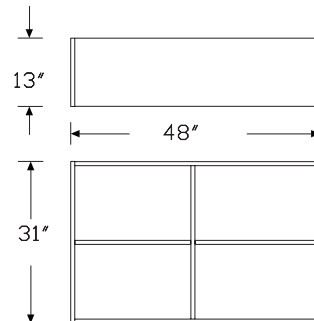
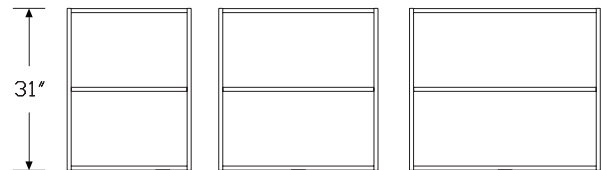
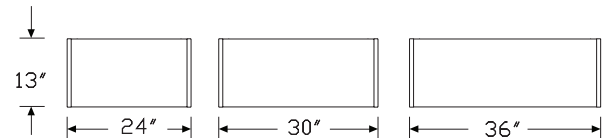
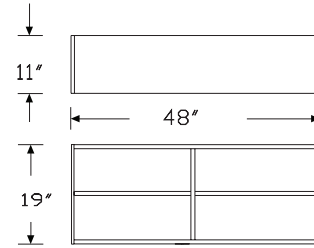
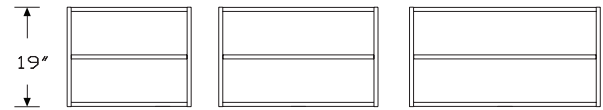
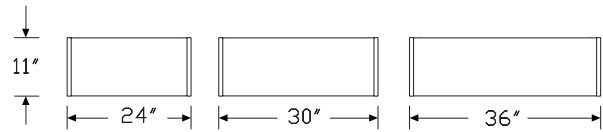

# Open Shelving Overheads *continued*

Mora™ Overhead Cabinets

Specification Information		
Step 1.		
<b>CH302.</b>		
Step 2. Height		
<b>31</b>	31" high	+\$575
Step 3. Width		
<b>24</b>	24" wide	-\$50
<b>30</b>	30" wide	+\$0
<b>36</b>	36" wide	+\$30
<b>48</b>	48" wide	+\$75
Step 4. Depth		
<b>13</b>	13" deep	+\$0
Step 5. Storage Options		
<b>O</b>	open shelves	+\$0
Step 6. Location in Run		
<b>S</b>	standalone	+\$0
<b>M</b>	middle of run	+\$0
<b>L</b>	left finished end	+\$0
<b>R</b>	right finished end	+\$0
Step 7. Surface Material		
<b>L</b>	low-pressure laminate	+\$0
<b>H</b>	high-pressure laminate	+\$200
Step 8. Grain Direction		
<b>HRG</b>	horizontal grain	+\$0
<b>VTG</b>	vertical grain	+\$0

## Step 9. Finish

### For low-pressure laminate (L)

<b>76</b>	light brown walnut	+\$0
<b>8Q</b>	folkstone grey	+\$0
<b>91</b>	white	+\$0
<b>98</b>	studio white	+\$0
<b>CL</b>	cool grey neutral	+\$0
<b>HM</b>	natural maple	+\$0
<b>HP</b>	light anigre	+\$0
<b>HX</b>	aged cherry	+\$0
<b>HY</b>	walnut on cherry	+\$0
<b>LA</b>	light ash	+\$0
<b>LBA</b>	clear on ash	+\$0
<b>LBR</b>	phantom ecru	+\$0
<b>LBS</b>	phantom cocoa	+\$0
<b>LBU</b>	medium matte walnut	+\$0
<b>LBV</b>	warm grey teak	+\$0
<b>LBB</b>	oak on ash	+\$0
<b>LBC</b>	walnut on ash	+\$0
<b>LBD</b>	dark brown walnut	+\$0
<b>LBE</b>	medium red walnut	+\$0
<b>LBF</b>	neutral twill	+\$0
<b>LBG</b>	sarum twill	+\$0
<b>LBH</b>	earthen twill	+\$0
<b>LBJ</b>	graphite twill	+\$0
<b>LBK</b>	pewter mesh	+\$0
<b>LBL</b>	steel mesh	+\$0
<b>LBM</b>	crisp linen	+\$0
<b>LBN</b>	classic linen	+\$0
<b>LBP</b>	casual linen	+\$0
<b>LBQ</b>	white twill	+\$0
<b>LU</b>	soft white	+\$0
<b>WL</b>	sandstone	+\$0
<b>WN</b>	warm grey neutral	+\$0

### For high-pressure laminate (H)

<b>76</b>	light brown walnut	+\$0
<b>8Q</b>	folkstone grey	+\$0
<b>91</b>	white	+\$0
<b>98</b>	studio white	+\$0
<b>CL</b>	cool grey neutral	+\$0
<b>HF</b>	inner tone light	+\$0
<b>HM</b>	natural maple	+\$0
<b>HP</b>	light anigre	+\$0
<b>HT</b>	inner tone	+\$0
<b>HX</b>	aged cherry	+\$0

## Open Shelving Overheads *continued*

<b>HY</b>	walnut on cherry	+\$0
<b>LA</b>	light ash	+\$0
<b>LBA</b>	clear on ash	+\$0
<b>LBR</b>	phantom ecru	+\$0
<b>LBS</b>	phantom cocoa	+\$0
<b>LBV</b>	warm grey teak	+\$0
<b>LBU</b>	medium matte walnut	+\$0
<b>LBB</b>	oak on ash	+\$0
<b>LBC</b>	walnut on ash	+\$0
<b>LBD</b>	dark brown walnut	+\$0
<b>LBE</b>	medium red walnut	+\$0
<b>LBF</b>	neutral twill	+\$0
<b>LBG</b>	sarum twill	+\$0
<b>LBH</b>	earthen twill	+\$0
<b>LBJ</b>	graphite twill	+\$0
<b>LBK</b>	pewter mesh	+\$0
<b>LBL</b>	steel mesh	+\$0
<b>LBM</b>	crisp linen	+\$0
<b>LBN</b>	classic linen	+\$0
<b>LBP</b>	casual linen	+\$0
<b>LBQ</b>	white twill	+\$0
<b>LM</b>	mahogany	+\$0
<b>LT</b>	light tone	+\$0
<b>LU</b>	soft white	+\$0
<b>MT</b>	medium tone	+\$0
<b>OL</b>	white oak (nonstandard)	+\$0
<b>WL</b>	sandstone	+\$0
<b>WN</b>	warm grey neutral	+\$0

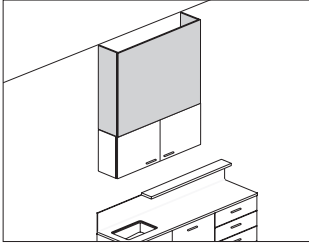

### Product Information

#### Description

This soffit sits on top of overhead storage cabinets to finish off the space between cabinet and ceiling. Soffit can span multiple cabinets. Attachment hardware included. Shipped knocked down.

#### Notes

Order overhead storage cabinets separately.

Default ceiling height is 9' AFF.

23"-high (23) soffit to be used with 30"-high overhead cabinets. Soffit depth is 13".

35"-high (35) soffit to be used with 19"-high overhead cabinets. Soffit depth is 11".

#### Dimensions

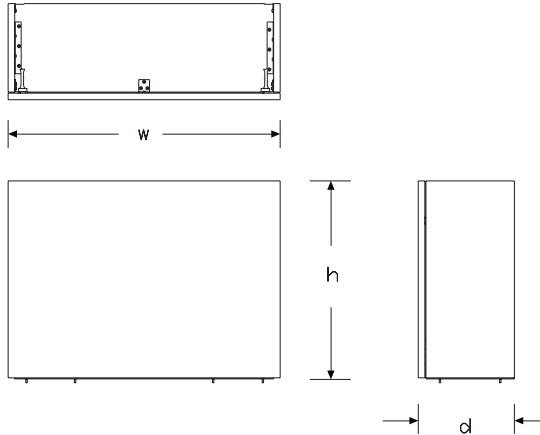

### Specification Information

#### Step 1.

#### CH320.

#### Step 2. Height

<b>23</b>	23" high	+\$680
<b>35</b>	35" high	+\$730

#### Step 3. Width

<b>30</b>	30" wide	+\$0
<b>36</b>	36" wide	+\$45
<b>42</b>	42" wide	+\$110
<b>48</b>	48" wide	+\$170
<b>54</b>	54" wide	+\$240
<b>60</b>	60" wide	+\$300
<b>66</b>	66" wide	+\$370
<b>72</b>	72" wide	+\$430

#### Step 4. Depth of Overhead Cabinets

##### For 35" high (35)

<b>11</b>	11" deep	+\$0
-----------	----------	------

##### For 23" high (23)

<b>13</b>	13" deep	+\$0
-----------	----------	------

#### Step 5. Material

<b>H</b>	high-pressure laminate	+\$240
<b>L</b>	low-pressure laminate	+\$0

#### Step 6. Grain Direction

##### For 30" wide (30), 36" wide (36), 42" wide (42), 48" wide (48), 54" wide (54), or 60" wide (60)

<b>HRG</b>	horizontal grain	+\$0
<b>VTG</b>	vertical grain	+\$0

##### For 66" wide (66) or 72" wide (72)

<b>HRG</b>	horizontal grain	+\$0
------------	------------------	------



Soffit *continued*

Step 7. Finish

*For low-pressure laminate (L)*

<b>76</b>	light brown walnut	+\$0
<b>8Q</b>	folkstone grey	+\$0
<b>91</b>	white	+\$0
<b>98</b>	studio white	+\$0
<b>CL</b>	cool grey neutral	+\$0
<b>HM</b>	natural maple	+\$0
<b>HP</b>	light anigre	+\$0
<b>HX</b>	aged cherry	+\$0
<b>HY</b>	walnut on cherry	+\$0
<b>LA</b>	light ash	+\$0
<b>LBA</b>	clear on ash	+\$0
<b>LBB</b>	oak on ash	+\$0
<b>LBC</b>	walnut on ash	+\$0
<b>LBD</b>	dark brown walnut	+\$0
<b>LBE</b>	medium red walnut	+\$0
<b>LBF</b>	neutral twill	+\$0
<b>LBG</b>	sarum twill	+\$0
<b>LBH</b>	earthen twill	+\$0
<b>LBJ</b>	graphite twill	+\$0
<b>LBK</b>	pewter mesh	+\$0
<b>LBL</b>	steel mesh	+\$0
<b>LBM</b>	crisp linen	+\$0
<b>LBN</b>	classic linen	+\$0
<b>LBP</b>	casual linen	+\$0
<b>LBQ</b>	white twill	+\$0
<b>LBR</b>	phantom ecru	+\$0
<b>LBS</b>	phantom cocoa	+\$0
<b>LBU</b>	medium matte walnut	+\$0
<b>LBV</b>	warm grey teak	+\$0
<b>LU</b>	soft white	+\$0
<b>WL</b>	sandstone	+\$0
<b>WN</b>	warm grey neutral	+\$0

*For high-pressure laminate (H)*

<b>76</b>	light brown walnut	+\$0
<b>8Q</b>	folkstone grey	+\$0
<b>91</b>	white	+\$0
<b>98</b>	studio white	+\$0
<b>CL</b>	cool grey neutral	+\$0
<b>HF</b>	inner tone light	+\$0
<b>HM</b>	natural maple	+\$0
<b>HP</b>	light anigre	+\$0
<b>HT</b>	inner tone	+\$0
<b>HX</b>	aged cherry	+\$0

<b>HY</b>	walnut on cherry	+\$0
<b>LA</b>	light ash	+\$0
<b>LBA</b>	clear on ash	+\$0
<b>LBB</b>	oak on ash	+\$0
<b>LBC</b>	walnut on ash	+\$0
<b>LBD</b>	dark brown walnut	+\$0
<b>LBE</b>	medium red walnut	+\$0
<b>LBF</b>	neutral twill	+\$0
<b>LBG</b>	sarum twill	+\$0
<b>LBH</b>	earthen twill	+\$0
<b>LBJ</b>	graphite twill	+\$0
<b>LBK</b>	pewter mesh	+\$0
<b>LBL</b>	steel mesh	+\$0
<b>LBM</b>	crisp linen	+\$0
<b>LBN</b>	classic linen	+\$0
<b>LBP</b>	casual linen	+\$0
<b>LBQ</b>	white twill	+\$0
<b>LBR</b>	phantom ecru	+\$0
<b>LBS</b>	phantom cocoa	+\$0
<b>LBU</b>	medium matte walnut	+\$0
<b>LBV</b>	warm grey teak	+\$0
<b>LM</b>	mahogany	+\$0
<b>LT</b>	light tone	+\$0
<b>LU</b>	soft white	+\$0
<b>MT</b>	medium tone	+\$0
<b>WL</b>	sandstone	+\$0
<b>WN</b>	warm grey neutral	+\$0

# Sloped Top Panel

CH315.

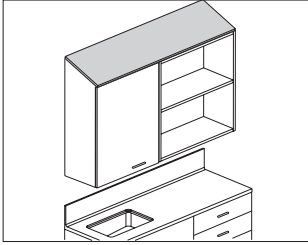

## Product Information

### Description

This panel attaches to an overhead storage cabinet to finish the sloped top. Panel can span multiple overhead storage cabinets.

### Notes

Order sloped top overhead storage cabinets (CH310., CH311., CH312.) separately.

### Dimensions

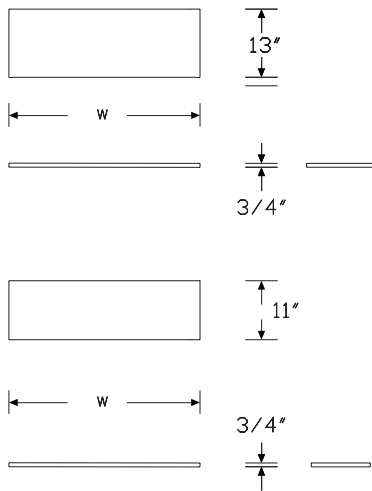

## Specification Information

### Step 1.

**CH315.**

### Step 2. Width

<b>18</b>	18" wide	+\$105
<b>24</b>	24" wide	+\$110
<b>30</b>	30" wide	+\$125
<b>36</b>	36" wide	+\$140
<b>42</b>	42" wide	+\$155
<b>48</b>	48" wide	+\$170
<b>54</b>	54" wide	+\$190
<b>60</b>	60" wide	+\$205
<b>66</b>	66" wide	+\$230
<b>72</b>	72" wide	+\$245

### Step 3. Depth

<b>11</b>	11" deep	+\$0
<b>13</b>	13" deep	+\$0

### Step 4. Material

<b>H</b>	high-pressure laminate	+\$125
<b>L</b>	low-pressure laminate	+\$0

### Step 5. Grain Direction

For 18" wide (18), 24" wide (24), 30" wide (30), 36" wide (36), 42" wide (42), 48" wide (48), 54" wide (54), or 60" wide (60)

<b>HRG</b>	horizontal grain <input type="checkbox"/>	+\$0
<b>VTG</b>	vertical grain <input type="checkbox"/>	+\$0

For 66" wide (66) or 72" wide (72)

<b>HRG</b>	horizontal grain <input type="checkbox"/>	+\$0
------------	---	------

# Sloped Top Panel *continued*

## Step 6. Finish

### *For low-pressure laminate (L)*

<b>76</b>	light brown walnut	+\$0
<b>8Q</b>	folkstone grey	+\$0
<b>91</b>	white	+\$0
<b>98</b>	studio white	+\$0
<b>CL</b>	cool grey neutral	+\$0
<b>HM</b>	natural maple	+\$0
<b>HP</b>	light anigre	+\$0
<b>HX</b>	aged cherry	+\$0
<b>HY</b>	walnut on cherry	+\$0
<b>LA</b>	light ash	+\$0
<b>LBA</b>	clear on ash	+\$0
<b>LBR</b>	phantom ecru	+\$0
<b>LBS</b>	phantom cocoa	+\$0
<b>LBU</b>	medium matte walnut	+\$0
<b>LBV</b>	warm grey teak	+\$0
<b>LBB</b>	oak on ash	+\$0
<b>LBC</b>	walnut on ash	+\$0
<b>LBD</b>	dark brown walnut	+\$0
<b>LBE</b>	medium red walnut	+\$0
<b>LBF</b>	neutral twill	+\$0
<b>LBG</b>	sarum twill	+\$0
<b>LBH</b>	earthen twill	+\$0
<b>LBJ</b>	graphite twill	+\$0
<b>LBK</b>	pewter mesh	+\$0
<b>LBL</b>	steel mesh	+\$0
<b>LBM</b>	crisp linen	+\$0
<b>LBN</b>	classic linen	+\$0
<b>LBP</b>	casual linen	+\$0
<b>LBQ</b>	white twill	+\$0
<b>LU</b>	soft white	+\$0
<b>WL</b>	sandstone	+\$0
<b>WN</b>	warm grey neutral	+\$0

### *For high-pressure laminate (H)*

<b>76</b>	light brown walnut	+\$0
<b>8Q</b>	folkstone grey	+\$0
<b>91</b>	white	+\$0
<b>98</b>	studio white	+\$0
<b>CL</b>	cool grey neutral	+\$0
<b>HF</b>	inner tone light	+\$0
<b>HM</b>	natural maple	+\$0
<b>HP</b>	light anigre	+\$0
<b>HT</b>	inner tone	+\$0
<b>HX</b>	aged cherry	+\$0

<b>HY</b>	walnut on cherry	+\$0
<b>LA</b>	light ash	+\$0
<b>LBA</b>	clear on ash	+\$0
<b>LBR</b>	phantom ecru	+\$0
<b>LBS</b>	phantom cocoa	+\$0
<b>LBU</b>	medium matte walnut	+\$0
<b>LBV</b>	warm grey teak	+\$0
<b>LBB</b>	oak on ash	+\$0
<b>LBC</b>	walnut on ash	+\$0
<b>LBD</b>	dark brown walnut	+\$0
<b>LBE</b>	medium red walnut	+\$0
<b>LBF</b>	neutral twill	+\$0
<b>LBG</b>	sarum twill	+\$0
<b>LBH</b>	earthen twill	+\$0
<b>LBJ</b>	graphite twill	+\$0
<b>LBK</b>	pewter mesh	+\$0
<b>LBL</b>	steel mesh	+\$0
<b>LBM</b>	crisp linen	+\$0
<b>LBN</b>	classic linen	+\$0
<b>LBP</b>	casual linen	+\$0
<b>LBQ</b>	white twill	+\$0
<b>LM</b>	mahogany	+\$0
<b>LT</b>	light tone	+\$0
<b>LU</b>	soft white	+\$0
<b>MT</b>	medium tone	+\$0
<b>OG</b>	honey maple	+\$0
<b>WL</b>	sandstone	+\$0
<b>WN</b>	warm grey neutral	+\$0

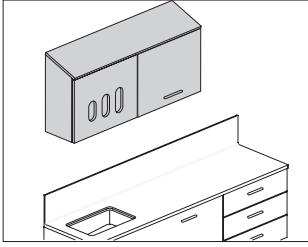

**Product Information**

**Description**

These overhead storage cabinets attach to an architectural wall with a hanging cleat. They are available in several sizes and storage configurations. All storage options include an adjustable shelf.

**Notes**

- Order sloped top panel (CH315.) separately.
- Order hanging cleat (CH100.) separately.
- Overhead cabinets wider than 36" have vertical divider.
- When specifying paper towel cabinet (P) or paper towel/glove holder combo cabinet (C), paper towel dispenser is field supplied.
- For keyed-alike locks, order lock plugs separately.

Mora™ Overhead Cabinets

**Dimensions**

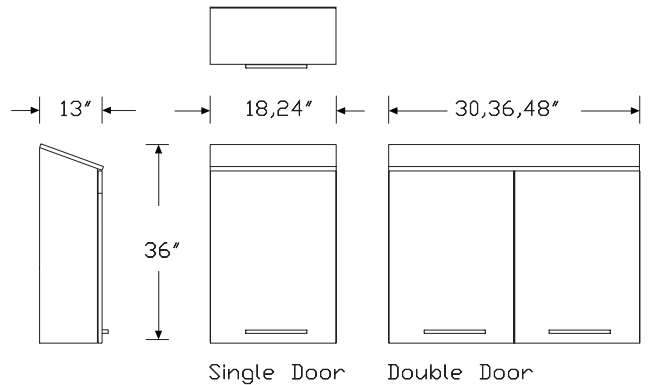
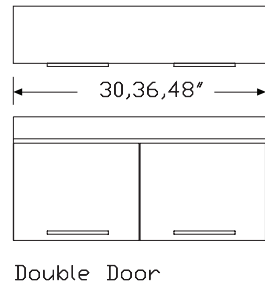
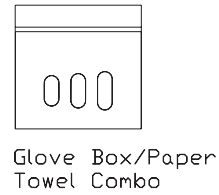
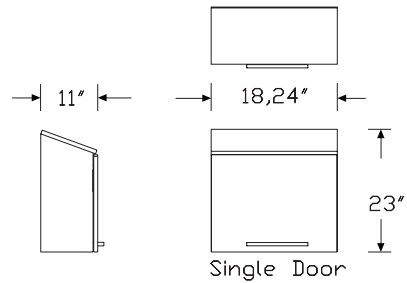

# Sloped Top Overhead Storage

continued

Mora™ Overhead Cabinets

## Specification Information

### Step 1.

**CH310.**

### Step 2. Height

<b>23</b>	23" high	+\$613
<b>36</b>	36" high	+\$731

### Step 3. Width

<b>18</b>	18" wide	-\$25
<b>24</b>	24" wide	+\$0
<b>30</b>	30" wide	+\$130
<b>36</b>	36" wide	+\$170
<b>48</b>	48" wide	+\$300

### Step 4. Depth

*For 23" high (23)*

<b>11</b>	11" deep	+\$0
-----------	----------	------

*For 36" high (36)*

<b>13</b>	13" deep	+\$0
-----------	----------	------

### Step 5. Storage Options

*For 23" high (23) with 18" wide (18) or 24" wide (24)*

<b>S</b>	single door	+\$0
<b>C</b>	paper towel/glove holder combo cabinet	+\$150
<b>P</b>	paper towel cabinet	+\$0
<b>G</b>	glove holder cabinet	+\$150

*For 36" high (36) with 18" wide (18) or 24" wide (24)*

<b>S</b>	single door	+\$0
<b>P</b>	paper towel cabinet	+\$0

*For 23" high (23) or 36" high (36) with 30" wide (30), 36" wide (36), or 48" wide (48)*

<b>D</b>	double door	+\$0
----------	-------------	------

### Step 6. Location in Run

<b>S</b>	standalone	+\$0
<b>M</b>	middle of run	+\$0
<b>L</b>	left end	+\$0
<b>R</b>	right end	+\$0

### Step 7. Door Hinge Location

*For single door (S), paper towel/glove holder combo cabinet (C), paper towel cabinet (P), or glove holder cabinet (G)*

<b>L</b>	left	+\$0
<b>R</b>	right	+\$0

*For double door (D)*

<b>S</b>	default	+\$0
----------	---------	------

### Step 8. Lock Option

*For double door (D) or single door (S)*

<b>NL</b>	no lock	+\$0
<b>KA</b>	keyed lock, keyed alike	+\$60
<b>KC</b>	keyed lock, keyed differently, chrome	+\$60
<b>KD</b>	keyed lock, keyed differently, black	+\$60
<b>KP</b>	keyless lock	+\$275

*For paper towel/glove holder combo cabinet (C), paper towel cabinet (P), or glove holder cabinet (G)*

<b>NL</b>	no lock	+\$0
-----------	---------	------

### Step 9. Pull Type

<b>A</b>	arc pull	+\$12
<b>K</b>	bar pull	+\$12
<b>T</b>	tab pull	+\$28
<b>P</b>	profile pull	+\$28
<b>C</b>	curved pull	+\$25
<b>N</b>	no pull	+\$0

### Step 10. Surface Material

<b>L</b>	low-pressure laminate	+\$0
<b>H</b>	high-pressure laminate	+\$240

### Step 11. Grain Direction

<b>HRG</b>	horizontal grain	+\$0
<b>VTG</b>	vertical grain	+\$0

# Sloped Top Overhead Storage

continued

Mora™ Overhead Cabinets

## Step 12. Finish

### For low-pressure laminate (L)

<b>76</b>	light brown walnut	+\$0
<b>8Q</b>	folkstone grey	+\$0
<b>91</b>	white	+\$0
<b>98</b>	studio white	+\$0
<b>CL</b>	cool grey neutral	+\$0
<b>HM</b>	natural maple	+\$0
<b>HP</b>	light anigre	+\$0
<b>HX</b>	aged cherry	+\$0
<b>HY</b>	walnut on cherry	+\$0
<b>LA</b>	light ash	+\$0
<b>LBA</b>	clear on ash	+\$0
<b>LBR</b>	phantom ecru	+\$0
<b>LBS</b>	phantom cocoa	+\$0
<b>LBU</b>	medium matte walnut	+\$0
<b>LBV</b>	warm grey teak	+\$0
<b>LBB</b>	oak on ash	+\$0
<b>LBC</b>	walnut on ash	+\$0
<b>LBD</b>	dark brown walnut	+\$0
<b>LBE</b>	medium red walnut	+\$0
<b>LBF</b>	neutral twill	+\$0
<b>LBG</b>	sarum twill	+\$0
<b>LBH</b>	earthen twill	+\$0
<b>LBJ</b>	graphite twill	+\$0
<b>LBK</b>	pewter mesh	+\$0
<b>LBL</b>	steel mesh	+\$0
<b>LBM</b>	crisp linen	+\$0
<b>LBN</b>	classic linen	+\$0
<b>LBP</b>	casual linen	+\$0
<b>LBQ</b>	white twill	+\$0
<b>LU</b>	soft white	+\$0
<b>WL</b>	sandstone	+\$0
<b>WN</b>	warm grey neutral	+\$0

### For high-pressure laminate (H)

<b>76</b>	light brown walnut	+\$0
<b>8Q</b>	folkstone grey	+\$0
<b>91</b>	white	+\$0
<b>98</b>	studio white	+\$0
<b>CL</b>	cool grey neutral	+\$0
<b>HF</b>	inner tone light	+\$0
<b>HM</b>	natural maple	+\$0
<b>HP</b>	light anigre	+\$0
<b>HT</b>	inner tone	+\$0
<b>HX</b>	aged cherry	+\$0

<b>HY</b>	walnut on cherry	+\$0
<b>LA</b>	light ash	+\$0
<b>LBA</b>	clear on ash	+\$0
<b>LBR</b>	phantom ecru	+\$0
<b>LBS</b>	phantom cocoa	+\$0
<b>LBV</b>	warm grey teak	+\$0
<b>LBU</b>	medium matte walnut	+\$0
<b>LBB</b>	oak on ash	+\$0
<b>LBC</b>	walnut on ash	+\$0
<b>LBD</b>	dark brown walnut	+\$0
<b>LBE</b>	medium red walnut	+\$0
<b>LBF</b>	neutral twill	+\$0
<b>LBG</b>	sarum twill	+\$0
<b>LBH</b>	earthen twill	+\$0
<b>LBJ</b>	graphite twill	+\$0
<b>LBK</b>	pewter mesh	+\$0
<b>LBL</b>	steel mesh	+\$0
<b>LBM</b>	crisp linen	+\$0
<b>LBN</b>	classic linen	+\$0
<b>LBP</b>	casual linen	+\$0
<b>LBQ</b>	white twill	+\$0
<b>LM</b>	mahogany	+\$0
<b>LT</b>	light tone	+\$0
<b>LU</b>	soft white	+\$0
<b>MT</b>	medium tone	+\$0
<b>OL</b>	white oak (nonstandard)	+\$0
<b>WL</b>	sandstone	+\$0
<b>WN</b>	warm grey neutral	+\$0

## Step 13. Pull Finish

### For no pull (N)

<b>NN</b>	no pull finish	+\$0
-----------	----------------	------

### For arc pull (A), tab pull (T), profile pull (P), or curved pull (C)

<b>STD</b>	standard finish	+\$0
------------	-----------------	------

### For bar pull (K)

<b>98</b>	studio white	+\$0
<b>8Q</b>	folkstone grey	+\$0
<b>91</b>	white	+\$0
<b>CN</b>	metallic champagne	+\$0
<b>G1</b>	graphite	+\$0
<b>MS</b>	metallic silver	+\$0

# Sloped Top Overhead Storage

*continued*

---

## Step 14. Grommet Finish

*For paper towel/glove holder combo cabinet (C) or glove holder cabinet (G)*

<b>8Q</b>	folkstone grey	+\$0
<b>91</b>	white	+\$0
<b>CL</b>	cool grey neutral	+\$0
<b>WL</b>	sandstone	+\$0
<b>WN</b>	warm grey neutral	+\$0

# Sloped Top Awning Overhead Storage

CH311.

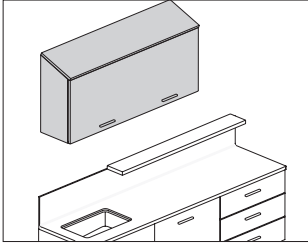

Mora™ Overhead Cabinets

## Product Information

**Description**  
 These overhead storage cabinets attach to an architectural wall with a hanging cleat. Cabinet includes an adjustable shelf.

## Notes

Order the following products separately:  
 • Hanging cleat (CH100.)  
 • Ganging hardware (CH110.)  
 Overhead cabinets wider than 36" have vertical divider.

## Dimensions

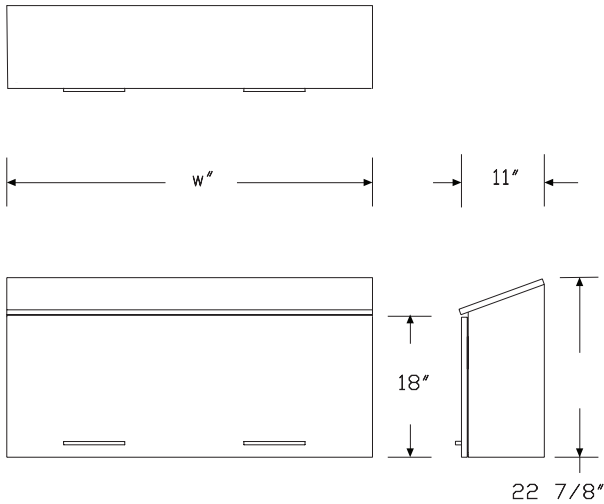

## Specification Information

**Step 1.**  
**CH311.**

**Step 2. Height**  
**23** 23" high +\$1036

**Step 3. Width**  
**30** 30" wide +\$0  
**36** 36" wide +\$75  
**48** 48" wide +\$175

**Step 4. Depth**  
**11** 11" deep +\$0

**Step 5. Storage Options**  
**A** awning door +\$0

**Step 6. Location in Run**  
**S** standalone +\$0  
**M** middle of run +\$0  
**L** left end +\$0  
**R** right end +\$0

**Step 7. Lock Option**  
**NL** no lock +\$0

**Step 8. Pull Type**  
**A** arc pull +\$12  
**K** bar pull +\$12  
**T** tab pull +\$28  
**P** profile pull +\$28  
**C** curved pull +\$25  
**N** no pull +\$0

**Step 9. Surface Material**  
**L** low-pressure laminate +\$0  
**H** high-pressure laminate +\$240

**Step 10. Grain Direction**  
**HRG** horizontal grain +\$0  
**VTG** vertical grain +\$0



# Sloped Top Awning Overhead Storage *continued*

## Step 11. Finish

### For low-pressure laminate (L)

<b>76</b>	light brown walnut	+\$0
<b>8Q</b>	folkstone grey	+\$0
<b>91</b>	white	+\$0
<b>98</b>	studio white	+\$0
<b>CL</b>	cool grey neutral	+\$0
<b>HM</b>	natural maple	+\$0
<b>HP</b>	light anigre	+\$0
<b>HX</b>	aged cherry	+\$0
<b>HY</b>	walnut on cherry	+\$0
<b>LA</b>	light ash	+\$0
<b>LBA</b>	clear on ash	+\$0
<b>LBR</b>	phantom ecru	+\$0
<b>LBS</b>	phantom cocoa	+\$0
<b>LBU</b>	medium matte walnut	+\$0
<b>LBV</b>	warm grey teak	+\$0
<b>LBB</b>	oak on ash	+\$0
<b>LBC</b>	walnut on ash	+\$0
<b>LBD</b>	dark brown walnut	+\$0
<b>LBE</b>	medium red walnut	+\$0
<b>LBF</b>	neutral twill	+\$0
<b>LBG</b>	sarum twill	+\$0
<b>LBH</b>	earthen twill	+\$0
<b>LBJ</b>	graphite twill	+\$0
<b>LBK</b>	pewter mesh	+\$0
<b>LBL</b>	steel mesh	+\$0
<b>LBM</b>	crisp linen	+\$0
<b>LBN</b>	classic linen	+\$0
<b>LBP</b>	casual linen	+\$0
<b>LBQ</b>	white twill	+\$0
<b>LU</b>	soft white	+\$0
<b>WL</b>	sandstone	+\$0
<b>WN</b>	warm grey neutral	+\$0

### For high-pressure laminate (H)

<b>76</b>	light brown walnut	+\$0
<b>8Q</b>	folkstone grey	+\$0
<b>91</b>	white	+\$0
<b>98</b>	studio white	+\$0
<b>CL</b>	cool grey neutral	+\$0
<b>HF</b>	inner tone light	+\$0
<b>HM</b>	natural maple	+\$0
<b>HP</b>	light anigre	+\$0
<b>HT</b>	inner tone	+\$0
<b>HX</b>	aged cherry	+\$0

<b>HY</b>	walnut on cherry	+\$0
<b>LA</b>	light ash	+\$0
<b>LBA</b>	clear on ash	+\$0
<b>LBR</b>	phantom ecru	+\$0
<b>LBS</b>	phantom cocoa	+\$0
<b>LBV</b>	warm grey teak	+\$0
<b>LBU</b>	medium matte walnut	+\$0
<b>LBB</b>	oak on ash	+\$0
<b>LBC</b>	walnut on ash	+\$0
<b>LBD</b>	dark brown walnut	+\$0
<b>LBE</b>	medium red walnut	+\$0
<b>LBF</b>	neutral twill	+\$0
<b>LBG</b>	sarum twill	+\$0
<b>LBH</b>	earthen twill	+\$0
<b>LBJ</b>	graphite twill	+\$0
<b>LBK</b>	pewter mesh	+\$0
<b>LBL</b>	steel mesh	+\$0
<b>LBM</b>	crisp linen	+\$0
<b>LBN</b>	classic linen	+\$0
<b>LBP</b>	casual linen	+\$0
<b>LBQ</b>	white twill	+\$0
<b>LM</b>	mahogany	+\$0
<b>LT</b>	light tone	+\$0
<b>LU</b>	soft white	+\$0
<b>MT</b>	medium tone	+\$0
<b>OL</b>	white oak (nonstandard)	+\$0
<b>WL</b>	sandstone	+\$0
<b>WN</b>	warm grey neutral	+\$0

## Step 12. Pull Finish

### For no pull (N)

<b>NN</b>	no pull finish	+\$0
-----------	----------------	------

### For arc pull (A), tab pull (T), profile pull (P), or curved pull (C)

<b>STD</b>	standard finish	+\$0
------------	-----------------	------

### For bar pull (K)

<b>98</b>	studio white	+\$0
<b>8Q</b>	folkstone grey	+\$0
<b>91</b>	white	+\$0
<b>G1</b>	graphite	+\$0
<b>CN</b>	metallic champagne	+\$0
<b>MS</b>	metallic silver	+\$0

Sloped Top Open Shelving  
Overheads

CH312.

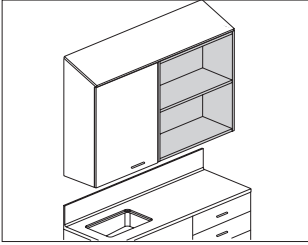

**Product Information**

**Description**  
These open-shelf overhead storage cabinets attach to an architectural wall with a hanging cleat. Cabinet includes an adjustable shelf.

**Notes**

Order the following products separately:  
 • Hanging cleat (CH100.)  
 • Ganging hardware (CH110.)  
 Overhead cabinets wider than 36" have vertical divider.

Mora™ Overhead Cabinets

**Dimensions**

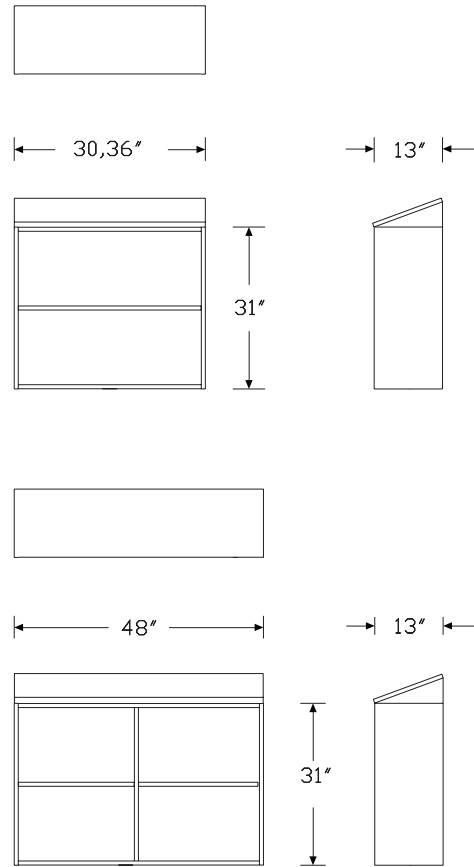

# Sloped Top Open Shelving Overheads *continued*

Specification Information		
Step 1.		
<b>CH312.</b>		
Step 2. Height		
<b>36</b>	36" high	+\$644
Step 3. Width		
<b>30</b>	30" wide	+\$0
<b>36</b>	36" wide	+\$30
<b>48</b>	48" wide	+\$75
Step 4. Depth		
<b>13</b>	13" deep	+\$0
Step 5. Storage Options		
<b>O</b>	open shelves	+\$0
Step 6. Location in Run		
<b>S</b>	standalone	+\$0
<b>M</b>	middle of run	+\$0
<b>L</b>	left finished end	+\$0
<b>R</b>	right finished end	+\$0
Step 7. Surface Material		
<b>L</b>	low-pressure laminate	+\$0
<b>H</b>	high-pressure laminate	+\$200
Step 8. Grain Direction		
<b>HRG</b>	horizontal grain	+\$0
<b>VTG</b>	vertical grain	+\$0

Step 9. Finish		
<i>For low-pressure laminate (L)</i>		
<b>76</b>	light brown walnut	+\$0
<b>8Q</b>	folkstone grey	+\$0
<b>91</b>	white	+\$0
<b>98</b>	studio white	+\$0
<b>CL</b>	cool grey neutral	+\$0
<b>HM</b>	natural maple	+\$0
<b>HP</b>	light anigre	+\$0
<b>HX</b>	aged cherry	+\$0
<b>HY</b>	walnut on cherry	+\$0
<b>LA</b>	light ash	+\$0
<b>LBA</b>	clear on ash	+\$0
<b>LBR</b>	phantom ecru	+\$0
<b>LBS</b>	phantom cocoa	+\$0
<b>LBU</b>	medium matte walnut	+\$0
<b>LBV</b>	warm grey teak	+\$0
<b>LBB</b>	oak on ash	+\$0
<b>LBC</b>	walnut on ash	+\$0
<b>LBD</b>	dark brown walnut	+\$0
<b>LBE</b>	medium red walnut	+\$0
<b>LBF</b>	neutral twill	+\$0
<b>LBG</b>	sarum twill	+\$0
<b>LBH</b>	earthen twill	+\$0
<b>LBJ</b>	graphite twill	+\$0
<b>LBK</b>	pewter mesh	+\$0
<b>LBL</b>	steel mesh	+\$0
<b>LBM</b>	crisp linen	+\$0
<b>LBN</b>	classic linen	+\$0
<b>LBP</b>	casual linen	+\$0
<b>LBQ</b>	white twill	+\$0
<b>LU</b>	soft white	+\$0
<b>WL</b>	sandstone	+\$0
<b>WN</b>	warm grey neutral	+\$0
<i>For high-pressure laminate (H)</i>		
<b>76</b>	light brown walnut	+\$0
<b>8Q</b>	folkstone grey	+\$0
<b>91</b>	white	+\$0
<b>98</b>	studio white	+\$0
<b>CL</b>	cool grey neutral	+\$0
<b>HF</b>	inner tone light	+\$0
<b>HM</b>	natural maple	+\$0
<b>HP</b>	light anigre	+\$0
<b>HT</b>	inner tone	+\$0
<b>HX</b>	aged cherry	+\$0

# Sloped Top Open Shelving Overheads *continued*

Mora™ Overhead Cabinets

<b>HY</b>	walnut on cherry	+\$0
<b>LA</b>	light ash	+\$0
<b>LBA</b>	clear on ash	+\$0
<b>LBR</b>	phantom ecru	+\$0
<b>LBS</b>	phantom cocoa	+\$0
<b>LBV</b>	warm grey teak	+\$0
<b>LBU</b>	medium matte walnut	+\$0
<b>LBB</b>	oak on ash	+\$0
<b>LBC</b>	walnut on ash	+\$0
<b>LBD</b>	dark brown walnut	+\$0
<b>LBE</b>	medium red walnut	+\$0
<b>LBF</b>	neutral twill	+\$0
<b>LBG</b>	sarum twill	+\$0
<b>LBH</b>	earthen twill	+\$0
<b>LBJ</b>	graphite twill	+\$0
<b>LBK</b>	pewter mesh	+\$0
<b>LBL</b>	steel mesh	+\$0
<b>LBM</b>	crisp linen	+\$0
<b>LBN</b>	classic linen	+\$0
<b>LBP</b>	casual linen	+\$0
<b>LBQ</b>	white twill	+\$0
<b>LM</b>	mahogany	+\$0
<b>LT</b>	light tone	+\$0
<b>LU</b>	soft white	+\$0
<b>MT</b>	medium tone	+\$0
<b>OL</b>	white oak (nonstandard)	+\$0
<b>WL</b>	sandstone	+\$0
<b>WN</b>	warm grey neutral	+\$0

# Tower Sloped Top Panel

CH316.

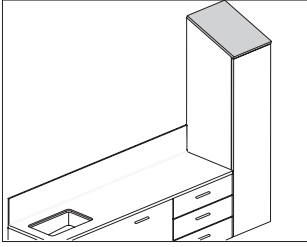

### Product Information

#### Description

This top panel attaches to and finishes a sloped-top tower cabinet.

#### Notes

Order sloped top tower cabinets separately.

#### Dimensions

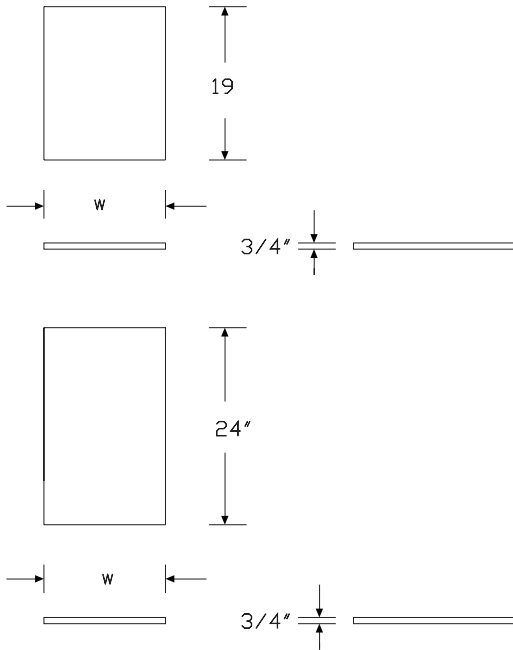

### Specification Information

#### Step 1.

**CH316.**  A

#### Step 2. Width

<b>15</b>	15" wide	<input type="checkbox"/> A	+\$130
<b>30</b>	30" wide	<input type="checkbox"/> A	+\$170
<b>45</b>	45" wide	<input type="checkbox"/> A	+\$210
<b>60</b>	60" wide	<input type="checkbox"/> A	+\$250
<b>75</b>	75" wide	<input type="checkbox"/> A	+\$290

#### Step 3. Depth

<b>19</b>	19" deep	<input type="checkbox"/> A	+\$0
<b>24</b>	24" deep	<input type="checkbox"/> A	+\$25

#### Step 4. Material

<b>H</b>	high-pressure laminate	<input type="checkbox"/> A	+\$125
<b>L</b>	low-pressure laminate	<input type="checkbox"/> A	+\$0

#### Step 5. Grain Direction

*For 15" wide (15), 30" wide (30), 45" wide (45), or 60" wide (60)*

<b>HRG</b>	horizontal grain	<input type="checkbox"/> A	+\$0
<b>VTG</b>	vertical grain	<input type="checkbox"/> A	+\$0

*For 75" wide (75)*

<b>HRG</b>	horizontal grain	<input type="checkbox"/> A	+\$0
------------	------------------	----------------------------	------

# Tower Sloped Top Panel *continued*

Mora™ Overhead Cabinets

## Step 6. Finish

### For low-pressure laminate (L)

<b>76</b>	light brown walnut <input type="checkbox"/>	+\$0
<b>8Q</b>	folkstone grey <input type="checkbox"/>	+\$0
<b>91</b>	white <input type="checkbox"/>	+\$0
<b>98</b>	studio white <input type="checkbox"/>	+\$0
<b>CL</b>	cool grey neutral <input type="checkbox"/>	+\$0
<b>HM</b>	natural maple <input type="checkbox"/>	+\$0
<b>HP</b>	light anigre <input type="checkbox"/>	+\$0
<b>HX</b>	aged cherry <input type="checkbox"/>	+\$0
<b>HY</b>	walnut on cherry <input type="checkbox"/>	+\$0
<b>LA</b>	light ash <input type="checkbox"/>	+\$0
<b>LBA</b>	clear on ash <input type="checkbox"/>	+\$0
<b>LBB</b>	oak on ash <input type="checkbox"/>	+\$0
<b>LBC</b>	walnut on ash <input type="checkbox"/>	+\$0
<b>LBD</b>	dark brown walnut <input type="checkbox"/>	+\$0
<b>LBE</b>	medium red walnut <input type="checkbox"/>	+\$0
<b>LBF</b>	neutral twill <input type="checkbox"/>	+\$0
<b>LBG</b>	sarum twill <input type="checkbox"/>	+\$0
<b>LBH</b>	earthen twill <input type="checkbox"/>	+\$0
<b>LBJ</b>	graphite twill <input type="checkbox"/>	+\$0
<b>LBK</b>	pewter mesh <input type="checkbox"/>	+\$0
<b>LBL</b>	steel mesh <input type="checkbox"/>	+\$0
<b>LBM</b>	crisp linen <input type="checkbox"/>	+\$0
<b>LBN</b>	classic linen <input type="checkbox"/>	+\$0
<b>LBP</b>	casual linen <input type="checkbox"/>	+\$0
<b>LBQ</b>	white twill <input type="checkbox"/>	+\$0
<b>LBR</b>	phantom ecru <input type="checkbox"/>	+\$0
<b>LBS</b>	phantom cocoa <input type="checkbox"/>	+\$0
<b>LBU</b>	medium matte walnut <input type="checkbox"/>	+\$0
<b>LBV</b>	warm grey teak <input type="checkbox"/>	+\$0
<b>LU</b>	soft white <input type="checkbox"/>	+\$0
<b>WL</b>	sandstone <input type="checkbox"/>	+\$0
<b>WN</b>	warm grey neutral <input type="checkbox"/>	+\$0

### For high-pressure laminate (H)

<b>LBR</b>	phantom ecru <input type="checkbox"/>	+\$0
<b>LBS</b>	phantom cocoa <input type="checkbox"/>	+\$0
<b>LBV</b>	warm grey teak <input type="checkbox"/>	+\$0
<b>76</b>	light brown walnut <input type="checkbox"/>	+\$0
<b>8Q</b>	folkstone grey <input type="checkbox"/>	+\$0
<b>91</b>	white <input type="checkbox"/>	+\$0
<b>98</b>	studio white <input type="checkbox"/>	+\$0
<b>CL</b>	cool grey neutral <input type="checkbox"/>	+\$0
<b>HF</b>	inner tone light <input type="checkbox"/>	+\$0
<b>HM</b>	natural maple <input type="checkbox"/>	+\$0

<b>HP</b>	light anigre <input type="checkbox"/>	+\$0
<b>HT</b>	inner tone <input type="checkbox"/>	+\$0
<b>HX</b>	aged cherry <input type="checkbox"/>	+\$0
<b>HY</b>	walnut on cherry <input type="checkbox"/>	+\$0
<b>LA</b>	light ash <input type="checkbox"/>	+\$0
<b>LBA</b>	clear on ash <input type="checkbox"/>	+\$0
<b>LBB</b>	oak on ash <input type="checkbox"/>	+\$0
<b>LBC</b>	walnut on ash <input type="checkbox"/>	+\$0
<b>LBD</b>	dark brown walnut <input type="checkbox"/>	+\$0
<b>LBE</b>	medium red walnut <input type="checkbox"/>	+\$0
<b>LBF</b>	neutral twill <input type="checkbox"/>	+\$0
<b>LBG</b>	sarum twill <input type="checkbox"/>	+\$0
<b>LBH</b>	earthen twill <input type="checkbox"/>	+\$0
<b>LBJ</b>	graphite twill <input type="checkbox"/>	+\$0
<b>LBK</b>	pewter mesh <input type="checkbox"/>	+\$0
<b>LBL</b>	steel mesh <input type="checkbox"/>	+\$0
<b>LBM</b>	crisp linen <input type="checkbox"/>	+\$0
<b>LBN</b>	classic linen <input type="checkbox"/>	+\$0
<b>LBP</b>	casual linen <input type="checkbox"/>	+\$0
<b>LBQ</b>	white twill <input type="checkbox"/>	+\$0
<b>LBU</b>	medium matte walnut <input type="checkbox"/>	+\$0
<b>LM</b>	mahogany <input type="checkbox"/>	+\$0
<b>LT</b>	light tone <input type="checkbox"/>	+\$0
<b>LU</b>	soft white <input type="checkbox"/>	+\$0
<b>MT</b>	medium tone <input type="checkbox"/>	+\$0
<b>WL</b>	sandstone <input type="checkbox"/>	+\$0
<b>WN</b>	warm grey neutral <input type="checkbox"/>	+\$0

# Wall-Mounted Door Towers

CH400.

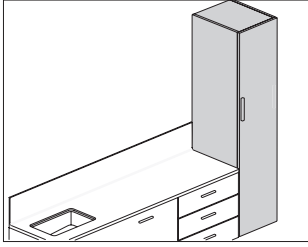

### Product Information

#### Description

The wall-mounted door towers attach to an architectural wall with a cleat. The towers provide easy access to storage or house gloves and trash. The trash tower is designed for a 10-gallon waste bin. The door towers have 2 adjustable shelves. The door tower shares a lower cleat with the adjacent product, and comes with 1 additional 15"-wide cleat to mount on the top location (separate 15"-wide cleat not included). Glove box holders are included but field installed.

#### Notes

When specifying side trash/glove access with interior shelving (T), waste bin not included. See Planning Guide for recommendations.

When specifying woodgrain laminate, grain direction is always vertical.

For keyed-alike locks, order lock plugs separately.

Order the following products separately:

- Hanging cleat (CH100.15)
- Ganging hardware (CH110.)

### Dimensions

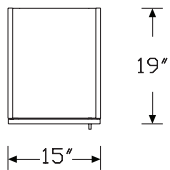

Shelves/  
Drawers

Shelves/  
Drawers

Gloves/  
Drawers

Gloves/  
Trash

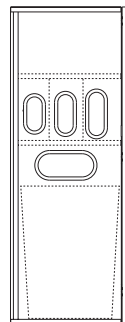
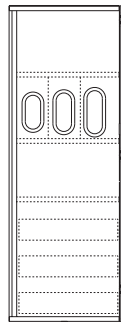
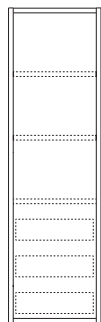
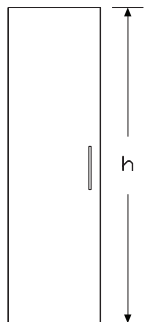

Front

Side

Side

### Specification Information

#### Step 1.

**CH400.**

#### Step 2. Width

**15** 15" wide +\$1650

#### Step 3. Depth

**19** 19" deep +\$0

#### Step 4. Height (off finished floor)

**66** 66" high +\$0

**74** 74" high +\$85

#### Step 5. Storage Options

**G** glove access and 3 pullout drawers +\$410

**S** shelves and 3 pullout drawers +\$260

**T** side trash/glove access with interior shelving +\$0

#### Step 6. Location in Run and Features

**L** left end, right handed +\$0

**R** right end, left handed +\$0

**S** standalone, left handed +\$0

**T** standalone, right handed +\$0

#### Step 7. Door Hinge Location

**L** left-hinged door +\$0

**R** right-hinged door +\$0

#### Step 8. Lock Option

**KA** keyed lock, keyed alike +\$60

**KC** keyed lock, keyed differently, chrome +\$60

**KD** keyed lock, keyed differently, black +\$60

**KP** keyless lock +\$275

**NL** no lock +\$0

#### Step 9. Pull Type

**A** arc pull +\$12

**C** curved pull +\$25

**K** bar pull +\$12

**N** no pull +\$0

**P** profile pull +\$28

**T** tab pull +\$28

#### Step 10. Surface Material

**H** high-pressure laminate +\$300

**L** low-pressure laminate +\$0

Mora™ Towers

# Wall-Mounted Door Towers *continued*

Mora™ Towers

## Step 11. Finish

### For low-pressure laminate (L)

<b>76</b>	light brown walnut	+\$0
<b>8Q</b>	folkstone grey	+\$0
<b>91</b>	white	+\$0
<b>98</b>	studio white	+\$0
<b>CL</b>	cool grey neutral	+\$0
<b>HM</b>	natural maple	+\$0
<b>HP</b>	light anigre	+\$0
<b>HX</b>	aged cherry	+\$0
<b>HY</b>	walnut on cherry	+\$0
<b>LA</b>	light ash	+\$0
<b>LBA</b>	clear on ash	+\$0
<b>LBR</b>	phantom ecru	+\$0
<b>LBS</b>	phantom cocoa	+\$0
<b>LBU</b>	medium matte walnut	+\$0
<b>LBV</b>	warm grey teak	+\$0
<b>LBB</b>	oak on ash	+\$0
<b>LBC</b>	walnut on ash	+\$0
<b>LBD</b>	dark brown walnut	+\$0
<b>LBE</b>	medium red walnut	+\$0
<b>LBF</b>	neutral twill	+\$0
<b>LBG</b>	sarum twill	+\$0
<b>LBH</b>	earthen twill	+\$0
<b>LBJ</b>	graphite twill	+\$0
<b>LBK</b>	pewter mesh	+\$0
<b>LBL</b>	steel mesh	+\$0
<b>LBM</b>	crisp linen	+\$0
<b>LBN</b>	classic linen	+\$0
<b>LBP</b>	casual linen	+\$0
<b>LBQ</b>	white twill	+\$0
<b>LU</b>	soft white	+\$0
<b>WL</b>	sandstone	+\$0
<b>WN</b>	warm grey neutral	+\$0

### For high-pressure laminate (H)

<b>76</b>	light brown walnut	+\$0
<b>8Q</b>	folkstone grey	+\$0
<b>91</b>	white	+\$0
<b>98</b>	studio white	+\$0
<b>CL</b>	cool grey neutral	+\$0
<b>HF</b>	inner tone light	+\$0
<b>HM</b>	natural maple	+\$0
<b>HP</b>	light anigre	+\$0
<b>HT</b>	inner tone	+\$0
<b>HX</b>	aged cherry	+\$0

<b>HY</b>	walnut on cherry	+\$0
<b>LA</b>	light ash	+\$0
<b>LBA</b>	clear on ash	+\$0
<b>LBR</b>	phantom ecru	+\$0
<b>LBS</b>	phantom cocoa	+\$0
<b>LBU</b>	medium matte walnut	+\$0
<b>LBV</b>	warm grey teak	+\$0
<b>LBB</b>	oak on ash	+\$0
<b>LBC</b>	walnut on ash	+\$0
<b>LBD</b>	dark brown walnut	+\$0
<b>LBE</b>	medium red walnut	+\$0
<b>LBF</b>	neutral twill	+\$0
<b>LBG</b>	sarum twill	+\$0
<b>LBH</b>	earthen twill	+\$0
<b>LBJ</b>	graphite twill	+\$0
<b>LBK</b>	pewter mesh	+\$0
<b>LBL</b>	steel mesh	+\$0
<b>LBM</b>	crisp linen	+\$0
<b>LBN</b>	classic linen	+\$0
<b>LBP</b>	casual linen	+\$0
<b>LBQ</b>	white twill	+\$0
<b>LM</b>	mahogany	+\$0
<b>LT</b>	light tone	+\$0
<b>LU</b>	soft white	+\$0
<b>MT</b>	medium tone	+\$0
<b>WL</b>	sandstone	+\$0
<b>WN</b>	warm grey neutral	+\$0

## Step 12. Pull Finish

### For no pull (N)

<b>NN</b>	no pull finish	+\$0
-----------	----------------	------

### For arc pull (A), curved pull (C), profile pull (P), or tab pull (T)

<b>STD</b>	standard finish	+\$0
------------	-----------------	------

### For bar pull (K)

<b>8Q</b>	folkstone grey	+\$0
<b>91</b>	white	+\$0
<b>98</b>	studio white	+\$0
<b>CN</b>	metallic champagne	+\$0
<b>G1</b>	graphite	+\$0
<b>MS</b>	metallic silver	+\$0



## Wall-Mounted Door Towers *continued*

---

### Step 13. Grommet Finish

*For glove access and 3 pullout drawers (G) or side trash/glove access with interior shelving (T)*

<b>8Q</b>	folkstone grey	+\$0
<b>91</b>	white	+\$0
<b>CL</b>	cool grey neutral	+\$0
<b>WL</b>	sandstone	+\$0
<b>WN</b>	warm grey neutral	+\$0

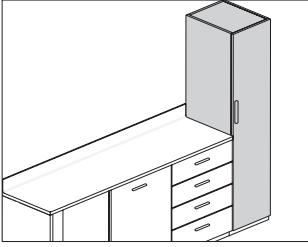

**Product Information**

**Description**  
 These towers sit on a plinth base with 1½" adjustable glides. They provide storage, easy access to gloves, and trash solutions. Towers with trash access are designed to hold a 10-gallon waste bin.

**Notes**  
 When specifying side glove and front trash access with interior shelving (C) or front trash access with interior shelving (T), waste bin not included. See Planning Guide for recommendations.  
 When specifying woodgrain laminate, grain direction is always vertical.  
 For keyed-alike locks, order lock plugs separately.  
 Order the following products separately:  
 • Plinth base (CH250. or CH255.)  
 • Ganging hardware (CH110.)

Mora™ Towers

**Dimensions**

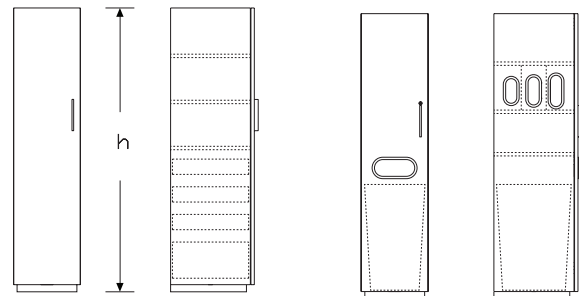
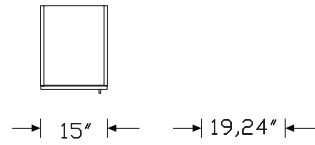

Shelves/Drawers (S)

Gloves/Trash (C)

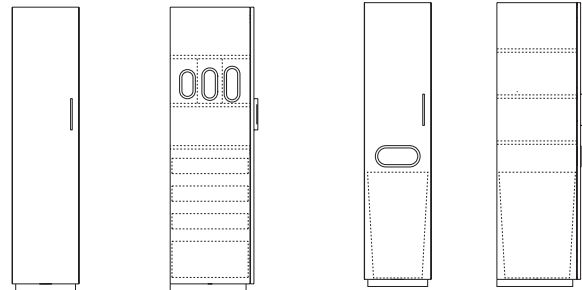

Gloves/Drawers (G)

Trash/Shelves (T)

To-The-Floor Door Towers *continued*

Specification Information		
Step 1.		
<b>CH405.</b>		
Step 2. Width		
<b>15</b>	15" wide	+\$1750
Step 3. Depth		
<b>19</b>	19" deep	+\$0
<b>24</b>	24" deep	+\$40
Step 4. Height (off finished floor)		
<b>66</b>	66" high	+\$0
<b>74</b>	74" high	+\$85
Step 5. Storage Options		
<b>C</b>	side glove and front trash and access with interior shelving	+\$0
<b>G</b>	glove access and 4 pullout drawers	+\$560
<b>S</b>	shelves and 4 pullout drawers	+\$400
<b>T</b>	front trash access with interior shelving	-\$50
Step 6. Location in Run and Features		
<b>L</b>	left end, right handed	+\$0
<b>R</b>	right end, left handed	+\$0
<b>S</b>	standalone, left handed	+\$0
<b>T</b>	standalone, right handed	+\$0
Step 7. Door Hinge Location		
<b>L</b>	left-hinged door	+\$0
<b>R</b>	right-hinged door	+\$0
Step 8. Lock Option		
<b>KA</b>	keyed lock, keyed alike	+\$60
<b>KC</b>	keyed lock, keyed differently, chrome	+\$60
<b>KD</b>	keyed lock, keyed differently, black	+\$60
<b>KP</b>	keyless lock	+\$275
<b>NL</b>	no lock	+\$0
Step 9. Pull Type		
<b>A</b>	arc pull	+\$12
<b>C</b>	curved pull	+\$25
<b>K</b>	bar pull	+\$12
<b>N</b>	no pull	+\$0
<b>P</b>	profile pull	+\$28
<b>T</b>	tab pull	+\$28

Step 10. Surface Material		
<b>H</b>	high-pressure laminate	+\$320
<b>L</b>	low-pressure laminate	+\$0
Step 11. Finish		
<i>For low-pressure laminate (L)</i>		
<b>76</b>	light brown walnut	+\$0
<b>8Q</b>	folkstone grey	+\$0
<b>91</b>	white	+\$0
<b>98</b>	studio white	+\$0
<b>CL</b>	cool grey neutral	+\$0
<b>HM</b>	natural maple	+\$0
<b>HP</b>	light anigre	+\$0
<b>HX</b>	aged cherry	+\$0
<b>HY</b>	walnut on cherry	+\$0
<b>LA</b>	light ash	+\$0
<b>LBA</b>	clear on ash	+\$0
<b>LBR</b>	phantom ecru	+\$0
<b>LBS</b>	phantom cocoa	+\$0
<b>LBU</b>	medium matte walnut	+\$0
<b>LBV</b>	warm grey teak	+\$0
<b>LBB</b>	oak on ash	+\$0
<b>LBC</b>	walnut on ash	+\$0
<b>LBD</b>	dark brown walnut	+\$0
<b>LBE</b>	medium red walnut	+\$0
<b>LBF</b>	neutral twill	+\$0
<b>LBG</b>	sarum twill	+\$0
<b>LBH</b>	earthen twill	+\$0
<b>LBJ</b>	graphite twill	+\$0
<b>LBK</b>	pewter mesh	+\$0
<b>LBL</b>	steel mesh	+\$0
<b>LBM</b>	crisp linen	+\$0
<b>LBN</b>	classic linen	+\$0
<b>LBP</b>	casual linen	+\$0
<b>LBQ</b>	white twill	+\$0
<b>LU</b>	soft white	+\$0
<b>WL</b>	sandstone	+\$0
<b>WN</b>	warm grey neutral	+\$0
<i>For high-pressure laminate (H)</i>		
<b>76</b>	light brown walnut	+\$0
<b>8Q</b>	folkstone grey	+\$0
<b>91</b>	white	+\$0
<b>98</b>	studio white	+\$0
<b>CL</b>	cool grey neutral	+\$0
<b>HF</b>	inner tone light	+\$0

To-The-Floor Door Towers *continued*

Mora™ Towers

<b>HM</b>	natural maple	+\$0
<b>HP</b>	light anigre	+\$0
<b>HT</b>	inner tone	+\$0
<b>HX</b>	aged cherry	+\$0
<b>HY</b>	walnut on cherry	+\$0
<b>LA</b>	light ash	+\$0
<b>LBA</b>	clear on ash	+\$0
<b>LBR</b>	phantom ecru	+\$0
<b>LBS</b>	phantom cocoa	+\$0
<b>LBU</b>	medium matte walnut	+\$0
<b>LBV</b>	warm grey teak	+\$0
<b>LBB</b>	oak on ash	+\$0
<b>LBC</b>	walnut on ash	+\$0
<b>LBD</b>	dark brown walnut	+\$0
<b>LBE</b>	medium red walnut	+\$0
<b>LBF</b>	neutral twill	+\$0
<b>LBG</b>	sarum twill	+\$0
<b>LBH</b>	earthen twill	+\$0
<b>LBJ</b>	graphite twill	+\$0
<b>LBK</b>	pewter mesh	+\$0
<b>LBL</b>	steel mesh	+\$0
<b>LBM</b>	crisp linen	+\$0
<b>LBN</b>	classic linen	+\$0
<b>LBP</b>	casual linen	+\$0
<b>LBQ</b>	white twill	+\$0
<b>LM</b>	mahogany	+\$0
<b>LT</b>	light tone	+\$0
<b>LU</b>	soft white	+\$0
<b>MT</b>	medium tone	+\$0
<b>WL</b>	sandstone	+\$0
<b>WN</b>	warm grey neutral	+\$0

Step 12. Pull Finish

*For no pull (N)*

<b>NN</b>	no pull finish	+\$0
-----------	----------------	------

*For arc pull (A), curved pull (C), profile pull (P), or tab pull (T)*

<b>STD</b>	standard finish	+\$0
------------	-----------------	------

*For bar pull (K)*

<b>8Q</b>	folkstone grey	+\$0
<b>91</b>	white	+\$0
<b>98</b>	studio white	+\$0
<b>CN</b>	metallic champagne	+\$0
<b>G1</b>	graphite	+\$0
<b>MS</b>	metallic silver	+\$0

Step 13. Grommet Finish  
*For side glove and front trash and access with interior shelving (C),  
glove access and 4 pullout drawers (G), or front trash access with  
interior shelving (T)*

<b>8Q</b>	folkstone grey	+\$0
<b>91</b>	white	+\$0
<b>CL</b>	cool grey neutral	+\$0
<b>WL</b>	sandstone	+\$0
<b>WN</b>	warm grey neutral	+\$0

# Sloped Top Wall-Mounted Door Towers

CH410.

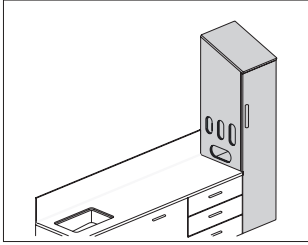

### Product Information

#### Description

The sloped-top wall-mounted door towers attach to an architectural wall with a cleat. The towers provide easy access to storage or house gloves and trash. The trash tower is designed for a 10-gallon waste bin. Glove box holders are included but field installed.

#### Notes

When specifying side trash/glove access with interior shelving (T), waste bin not included. See Planning Guide for recommendations.

When specifying woodgrain laminate, grain direction is always vertical. Sloped top grain direction should match the grain direction of adjacent sloped top panels.

For keyed-alike locks, order lock plugs separately.

Order the following products separately:

- Tower sloped top panel (CH316.)
- Hanging cleat (CH100.15)
- Ganging hardware (CH110.)

### Dimensions

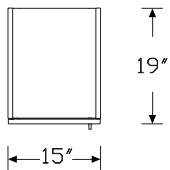

Shelves/Drawers (S)      Gloves/Drawers (G)      Gloves/Trash (T)

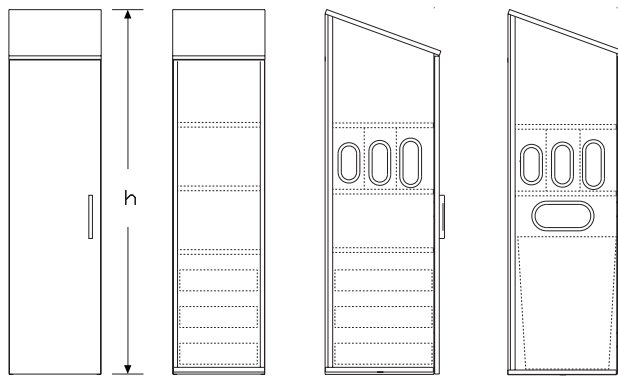

Front

Side

Side

### Specification Information

#### Step 1.

**CH410.**

#### Step 2. Width

**15**    15" wide    +\$1848

#### Step 3. Depth

**19**    19" deep    +\$0

#### Step 4. Height (off finished floor)

**78**    78" high    +\$0

#### Step 5. Storage Options

<b>S</b>	shelves and 3 pullout drawers	+\$260
<b>G</b>	glove access and 3 pullout drawers	+\$410
<b>T</b>	side trash/glove access with interior shelving	+\$0

#### Step 6. Location in Run and Features

##### For shelves and 3 pullout drawers (S)

<b>L</b>	left end, right handed	+\$0
<b>R</b>	right end, left handed	+\$0
<b>S</b>	standalone	+\$0

##### For glove access and 3 pullout drawers (G) or side trash/glove access with interior shelving (T)

<b>L</b>	left end, right handed	+\$0
<b>R</b>	right end, left handed	+\$0
<b>S</b>	standalone, left handed	+\$0
<b>T</b>	standalone, right handed	+\$0

#### Step 7. Door Hinge Location

<b>L</b>	left-hinged door	+\$0
<b>R</b>	right-hinged door	+\$0

#### Step 8. Lock Option

<b>NL</b>	no lock	+\$0
<b>KA</b>	keyed lock, keyed alike	+\$60
<b>KC</b>	keyed lock, keyed differently, chrome	+\$60
<b>KD</b>	keyed lock, keyed differently, black	+\$60
<b>KP</b>	keyless lock	+\$275

Mora™ Towers

# Sloped Top Wall-Mounted Door Towers *continued*

Mora™ Towers

Step 9. Pull Type		
<b>A</b>	arc pull	+\$12
<b>C</b>	curved pull	+\$25
<b>K</b>	bar pull	+\$12
<b>N</b>	no pull	+\$0
<b>P</b>	profile pull	+\$28
<b>T</b>	tab pull	+\$28

Step 10. Surface Material		
<b>H</b>	high-pressure laminate	+\$300
<b>L</b>	low-pressure laminate	+\$0

Step 11. Case Finish		
----------------------	--	--

<i>For low-pressure laminate (L)</i>		
<b>76</b>	light brown walnut	+\$0
<b>8Q</b>	folkstone grey	+\$0
<b>91</b>	white	+\$0
<b>98</b>	studio white	+\$0
<b>CL</b>	cool grey neutral	+\$0
<b>HM</b>	natural maple	+\$0
<b>HP</b>	light anigre	+\$0
<b>HX</b>	aged cherry	+\$0
<b>HY</b>	walnut on cherry	+\$0
<b>LA</b>	light ash	+\$0
<b>LBA</b>	clear on ash	+\$0
<b>LBB</b>	oak on ash	+\$0
<b>LBC</b>	walnut on ash	+\$0
<b>LBD</b>	dark brown walnut	+\$0
<b>LBE</b>	medium red walnut	+\$0
<b>LBF</b>	neutral twill	+\$0
<b>LBG</b>	sarum twill	+\$0
<b>LBH</b>	earthen twill	+\$0
<b>LBJ</b>	graphite twill	+\$0
<b>LBK</b>	pewter mesh	+\$0
<b>LBL</b>	steel mesh	+\$0
<b>LBM</b>	crisp linen	+\$0
<b>LBN</b>	classic linen	+\$0
<b>LBP</b>	casual linen	+\$0
<b>LBQ</b>	white twill	+\$0
<b>LM</b>	mahogany	+\$0
<b>LT</b>	light tone	+\$0
<b>LU</b>	soft white	+\$0
<b>WL</b>	sandstone	+\$0
<b>WN</b>	warm grey neutral	+\$0

<i>For high-pressure laminate (H)</i>		
<b>76</b>	light brown walnut	+\$0
<b>8Q</b>	folkstone grey	+\$0
<b>91</b>	white	+\$0
<b>98</b>	studio white	+\$0
<b>CL</b>	cool grey neutral	+\$0
<b>HF</b>	inner tone light	+\$0
<b>HM</b>	natural maple	+\$0
<b>HP</b>	light anigre	+\$0
<b>HT</b>	inner tone	+\$0
<b>HX</b>	aged cherry	+\$0
<b>HY</b>	walnut on cherry	+\$0
<b>LA</b>	light ash	+\$0
<b>LBA</b>	clear on ash	+\$0
<b>LBB</b>	oak on ash	+\$0
<b>LBC</b>	walnut on ash	+\$0
<b>LBD</b>	dark brown walnut	+\$0
<b>LBE</b>	medium red walnut	+\$0
<b>LBF</b>	neutral twill	+\$0
<b>LBG</b>	sarum twill	+\$0
<b>LBH</b>	earthen twill	+\$0
<b>LBJ</b>	graphite twill	+\$0
<b>LBK</b>	pewter mesh	+\$0
<b>LBL</b>	steel mesh	+\$0
<b>LBM</b>	crisp linen	+\$0
<b>LBN</b>	classic linen	+\$0
<b>LBP</b>	casual linen	+\$0
<b>LBQ</b>	white twill	+\$0
<b>LM</b>	mahogany	+\$0
<b>LT</b>	light tone	+\$0
<b>LU</b>	soft white	+\$0
<b>MT</b>	medium tone	+\$0
<b>WL</b>	sandstone	+\$0
<b>WN</b>	warm grey neutral	+\$0

Step 12. Pull Finish		
<i>For no pull (N)</i>		
<b>NN</b>	no pull finish	+\$0
<i>For arc pull (A), curved pull (C), profile pull (P), or tab pull (T)</i>		
<b>STD</b>	standard finish	+\$0

# Sloped Top Wall-Mounted Door Towers *continued*

---

*For bar pull (K)*

<b>8Q</b>	folkstone grey	+\$0
<b>91</b>	white	+\$0
<b>98</b>	studio white	+\$0
<b>CN</b>	metallic champagne	+\$0
<b>G1</b>	graphite	+\$0
<b>MS</b>	metallic silver	+\$0

---

Step 13. Grommet Finish

*For glove access and 3 pullout drawers (G) or side trash/glove access with interior shelving (T)*

<b>8Q</b>	folkstone grey	+\$0
<b>91</b>	white	+\$0
<b>CL</b>	cool grey neutral	+\$0
<b>WL</b>	sandstone	+\$0
<b>WN</b>	warm grey neutral	+\$0

# Sloped Top To-the-Floor Door Towers

CH415.

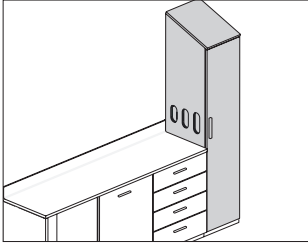

## Product Information

### Description

These sloped-top towers sit on a plinth base with 1½" adjustable glides. They provide storage, easy access to gloves, and trash solutions. Towers with trash access are designed to hold a 10-gallon waste bin.

### Notes

When specifying side glove and front trash access with interior shelving (C) or front trash access with interior shelving (T), waste bin not included. See Planning Guide for recommendations.

When specifying woodgrain laminate, grain direction is always vertical. Sloped top grain direction should match the grain direction of adjacent sloped top panels.

For keyed-alike locks, order lock plugs separately.

Order the following products separately:

- Tower sloped top panel (CH316.)
- Plinth base (CH250. or CH255.)
- Ganging hardware (CH110.)

Mora™ Towers

## Dimensions



→ 15" ←      → 19,24" ←

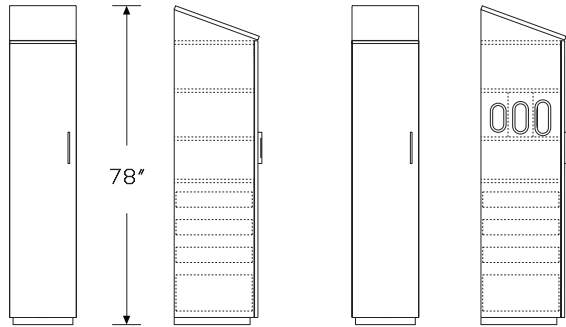

Shelves/Drawers (S)

Gloves/Drawers (G)

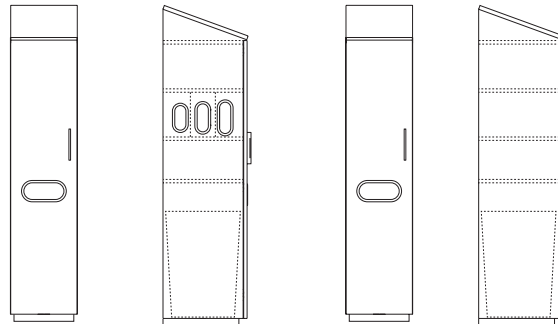

Gloves/Trash (C)

Trash/Shelves (T)



# Sloped Top To-the-Floor Door Towers *continued*

## Specification Information

Step 1.  
**CH415.**

Step 2. Width  
**15** 15" wide +\$2055

Step 3. Depth  
**19** 19" deep +\$0  
**24** 24" deep +\$40

Step 4. Height (off finished floor)  
**78** 78" high +\$0

Step 5. Storage Options  
**S** shelves and 4 pullout drawers +\$400  
**G** glove access and 4 pullout drawers +\$560  
**C** side glove and front trash and access with interior shelving +\$0  
**T** front trash access with interior shelving -\$50

Step 6. Location in Run and Features

*For shelves and 4 pullout drawers (S) or front trash access with interior shelving (T)*  
**S** standalone +\$0

*For glove access and 4 pullout drawers (G) or side glove and front trash and access with interior shelving (C)*  
**L** left end, right handed +\$0  
**R** right end, left handed +\$0

Step 7. Door Hinge Location  
**L** left hinged +\$0  
**R** right hinged +\$0

Step 8. Lock Option  
**NL** no lock +\$0  
**KA** keyed lock, keyed alike +\$60  
**KC** keyed lock, keyed differently, chrome +\$60  
**KD** keyed lock, keyed differently, black +\$60  
**KP** keyless lock +\$275

Step 9. Pull Type  
**A** arc pull +\$12  
**K** bar pull +\$12  
**T** tab pull +\$28  
**P** profile pull +\$28  
**C** curved pull +\$25  
**N** no pull +\$0

Step 10. Surface Material  
**H** high-pressure laminate +\$320  
**L** low-pressure laminate +\$0

Step 11. Case Finish

*For low-pressure laminate (L)*  
**76** light brown walnut +\$0  
**8Q** folkstone grey +\$0  
**91** white +\$0  
**98** studio white +\$0  
**CL** cool grey neutral +\$0  
**HM** natural maple +\$0  
**HP** light anigre +\$0  
**HX** aged cherry +\$0  
**HY** walnut on cherry +\$0  
**LA** light ash +\$0  
**LBA** clear on ash +\$0  
**LBB** oak on ash +\$0  
**LBC** walnut on ash +\$0  
**LBD** dark brown walnut +\$0  
**LBE** medium red walnut +\$0  
**LBF** neutral twill +\$0  
**LBG** sarum twill +\$0  
**LBH** earthen twill +\$0  
**LBJ** graphite twill +\$0  
**LBK** pewter mesh +\$0  
**LBL** steel mesh +\$0  
**LBM** crisp linen +\$0  
**LBN** classic linen +\$0  
**LBP** casual linen +\$0  
**LBQ** white twill +\$0  
**LU** soft white +\$0  
**WL** sandstone +\$0  
**WN** warm grey neutral +\$0

Mora™ Towers

# Sloped Top To-the-Floor Door Towers *continued*

Mora™ Towers

*For high-pressure laminate (H)*

<b>76</b>	light brown walnut	+\$0
<b>8Q</b>	folkstone grey	+\$0
<b>91</b>	white	+\$0
<b>98</b>	studio white	+\$0
<b>CL</b>	cool grey neutral	+\$0
<b>HF</b>	inner tone light	+\$0
<b>HM</b>	natural maple	+\$0
<b>HP</b>	light anigre	+\$0
<b>HT</b>	inner tone	+\$0
<b>HX</b>	aged cherry	+\$0
<b>HY</b>	walnut on cherry	+\$0
<b>LA</b>	light ash	+\$0
<b>LBA</b>	clear on ash	+\$0
<b>LBB</b>	oak on ash	+\$0
<b>LBC</b>	walnut on ash	+\$0
<b>LBD</b>	dark brown walnut	+\$0
<b>LBE</b>	medium red walnut	+\$0
<b>LBF</b>	neutral twill	+\$0
<b>LBG</b>	sarum twill	+\$0
<b>LBH</b>	earthen twill	+\$0
<b>LBJ</b>	graphite twill	+\$0
<b>LBK</b>	pewter mesh	+\$0
<b>LBL</b>	steel mesh	+\$0
<b>LBM</b>	crisp linen	+\$0
<b>LBN</b>	classic linen	+\$0
<b>LBP</b>	casual linen	+\$0
<b>LBQ</b>	white twill	+\$0
<b>LM</b>	mahogany	+\$0
<b>LT</b>	light tone	+\$0
<b>LU</b>	soft white	+\$0
<b>MT</b>	medium tone	+\$0
<b>WL</b>	sandstone	+\$0
<b>WN</b>	warm grey neutral	+\$0

Step 12. Pull Finish

*For no pull (N)*

<b>NN</b>	no pull finish	+\$0
-----------	----------------	------

*For arc pull (A), tab pull (T), profile pull (P), or curved pull (C)*

<b>STD</b>	standard finish	+\$0
------------	-----------------	------

*For bar pull (K)*

<b>8Q</b>	folkstone grey	+\$0
<b>91</b>	white	+\$0
<b>98</b>	studio white	+\$0
<b>CN</b>	metallic champagne	+\$0
<b>G1</b>	graphite	+\$0
<b>MS</b>	metallic silver	+\$0

Step 13. Grommet Finish

*For glove access and 4 pullout drawers (G), side glove and front trash and access with interior shelving (C), or front trash access with interior shelving (T)*

<b>8Q</b>	folkstone grey	+\$0
<b>91</b>	white	+\$0
<b>CL</b>	cool grey neutral	+\$0
<b>WL</b>	sandstone	+\$0
<b>WN</b>	warm grey neutral	+\$0

# Wall-Mounted Shelf Towers

CH420.

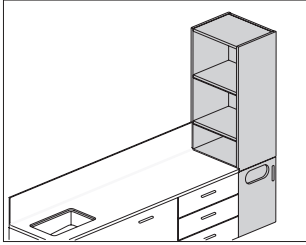

### Product Information

#### Description

This wall-mounted shelf tower attaches to an architectural wall with a wall rail. The tower provides easy access to storage. The trash access tower accommodates a 7-gallon waste bin.

#### Notes

Waste bin not included. See Planning Guide for recommendations.

Shelves are adjustable: 1 shelf on 66"-high tower; 2 shelves on 74"-high tower.

When specifying wood-grain laminate, grain direction is always vertical. Order ganging hardware pack (CH110.) separately.

#### Dimensions

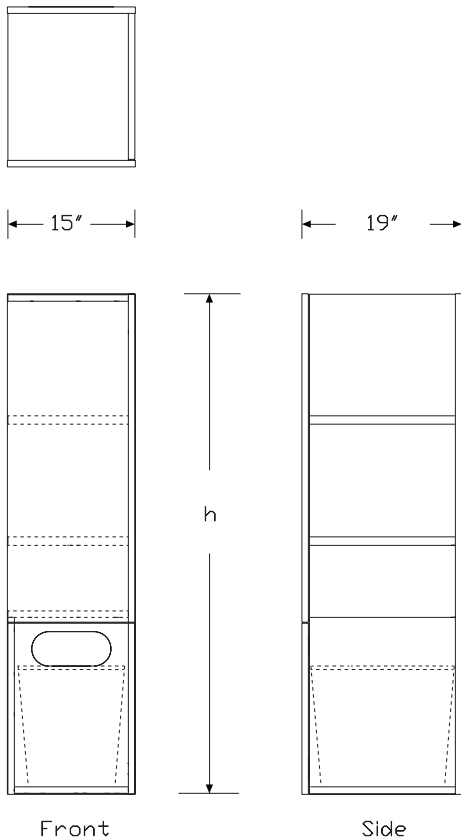

### Specification Information

#### Step 1.

**CH420.**

#### Step 2. Width

**15** 15" wide +\$1785

#### Step 3. Depth

**19** 19" deep +\$0

#### Step 4. Height (off finished floor)

**66** 66" high +\$0

**74** 74" high +\$85

#### Step 5. Storage Options

**T** open side shelves, trash access +\$0

#### Step 6. Location in Run and Features

**L** left end, right handed +\$0

**R** right end, left handed +\$0

**S** standalone, left handed +\$0

**T** standalone, right handed +\$0

#### Step 7. Hinge Location

**L** left-hinged door +\$0

**R** right-hinged door +\$0

#### Step 8. Pull Type

**A** arc pull +\$12

**C** curved pull +\$25

**K** bar pull +\$12

**N** no pull +\$0

**P** profile pull +\$28

**T** tab pull +\$28

#### Step 9. Surface Material

**H** high-pressure laminate +\$225

**L** low-pressure laminate +\$0

Mora™ Towers

# Wall-Mounted Shelf Towers

continued

Mora™ Towers

## Step 10. Finish

### For low-pressure laminate (L)

<b>76</b>	light brown walnut	+\$0
<b>8Q</b>	folkstone grey	+\$0
<b>91</b>	white	+\$0
<b>98</b>	studio white	+\$0
<b>CL</b>	cool grey neutral	+\$0
<b>HM</b>	natural maple	+\$0
<b>HP</b>	light anigre	+\$0
<b>HX</b>	aged cherry	+\$0
<b>HY</b>	walnut on cherry	+\$0
<b>LA</b>	light ash	+\$0
<b>LBA</b>	clear on ash	+\$0
<b>LBR</b>	phantom ecru	+\$0
<b>LBS</b>	phantom cocoa	+\$0
<b>LBU</b>	medium matte walnut	+\$0
<b>LBV</b>	warm grey teak	+\$0
<b>LBB</b>	oak on ash	+\$0
<b>LBC</b>	walnut on ash	+\$0
<b>LBD</b>	dark brown walnut	+\$0
<b>LBE</b>	medium red walnut	+\$0
<b>LBF</b>	neutral twill	+\$0
<b>LBG</b>	sarum twill	+\$0
<b>LBH</b>	earthen twill	+\$0
<b>LBJ</b>	graphite twill	+\$0
<b>LBK</b>	pewter mesh	+\$0
<b>LBL</b>	steel mesh	+\$0
<b>LBM</b>	crisp linen	+\$0
<b>LBN</b>	classic linen	+\$0
<b>LBP</b>	casual linen	+\$0
<b>LBQ</b>	white twill	+\$0
<b>LU</b>	soft white	+\$0
<b>WL</b>	sandstone	+\$0
<b>WN</b>	warm grey neutral	+\$0

### For high-pressure laminate (H)

<b>76</b>	light brown walnut	+\$0
<b>8Q</b>	folkstone grey	+\$0
<b>91</b>	white	+\$0
<b>98</b>	studio white	+\$0
<b>CL</b>	cool grey neutral	+\$0
<b>HF</b>	inner tone light	+\$0
<b>HM</b>	natural maple	+\$0
<b>HP</b>	light anigre	+\$0
<b>HT</b>	inner tone	+\$0
<b>HX</b>	aged cherry	+\$0

<b>HY</b>	walnut on cherry	+\$0
<b>LA</b>	light ash	+\$0
<b>LBA</b>	clear on ash	+\$0
<b>LBR</b>	phantom ecru	+\$0
<b>LBS</b>	phantom cocoa	+\$0
<b>LBU</b>	medium matte walnut	+\$0
<b>LBV</b>	warm grey teak	+\$0
<b>LBB</b>	oak on ash	+\$0
<b>LBC</b>	walnut on ash	+\$0
<b>LBD</b>	dark brown walnut	+\$0
<b>LBE</b>	medium red walnut	+\$0
<b>LBF</b>	neutral twill	+\$0
<b>LBG</b>	sarum twill	+\$0
<b>LBH</b>	earthen twill	+\$0
<b>LBJ</b>	graphite twill	+\$0
<b>LBK</b>	pewter mesh	+\$0
<b>LBL</b>	steel mesh	+\$0
<b>LBM</b>	crisp linen	+\$0
<b>LBN</b>	classic linen	+\$0
<b>LBP</b>	casual linen	+\$0
<b>LBQ</b>	white twill	+\$0
<b>LM</b>	mahogany	+\$0
<b>LT</b>	light tone	+\$0
<b>LU</b>	soft white	+\$0
<b>MT</b>	medium tone	+\$0
<b>OG</b>	honey maple	+\$0
<b>WL</b>	sandstone	+\$0
<b>WN</b>	warm grey neutral	+\$0

## Step 11. Pull Finish

### For no pull (N)

<b>NN</b>	no pull finish	+\$0
-----------	----------------	------

### For arc pull (A), curved pull (C), profile pull (P), or tab pull (T)

<b>STD</b>	standard finish	+\$0
------------	-----------------	------

### For bar pull (K)

<b>98</b>	studio white	+\$0
<b>8Q</b>	folkstone grey	+\$0
<b>91</b>	white	+\$0
<b>G1</b>	graphite	+\$0
<b>CN</b>	metallic champagne	+\$0
<b>MS</b>	metallic silver	+\$0

## Wall-Mounted Shelf Towers

*continued*

---

### Step 12. Grommet Finish

<b>8Q</b>	folkstone grey	+\$0
<b>91</b>	white	+\$0
<b>CL</b>	cool grey neutral	+\$0
<b>WL</b>	sandstone	+\$0
<b>WN</b>	warm grey neutral	+\$0

# 1" Shelf for Shelf Towers

CH421.

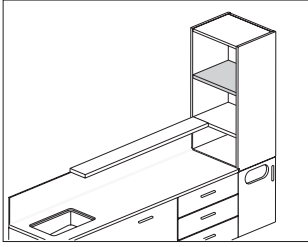

## Product Information

### Description

This 1"-thick shelf replaces the standard shelf in a shelf tower when a floating shelf is used next to it.

### Notes

Order shelf tower (CH420.) separately.

### Dimensions

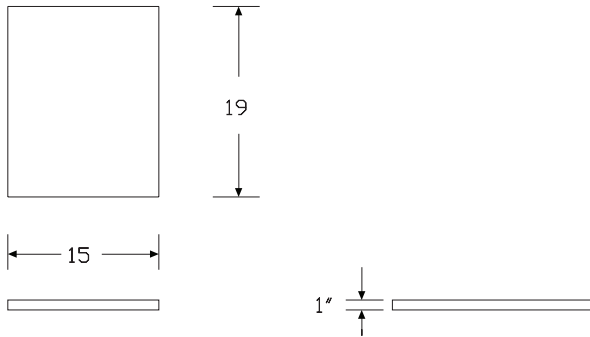

Mora™ Towers

## Specification Information

### Step 1.

**CH421.**

### Step 2. Width

**15** 15" wide  +\$110

### Step 3. Depth

**19** 19" deep  +\$0

### Step 4. Surface Material

**H** high-pressure laminate  +\$0

### Step 5. Finish

- 76** light brown walnut  +\$0
- 8Q** folkstone grey  +\$0
- 91** white  +\$0
- 98** studio white  +\$0
- CL** cool grey neutral  +\$0
- HF** inner tone light  +\$0
- HM** natural maple  +\$0
- HP** light anigre  +\$0
- HT** inner tone  +\$0
- HX** aged cherry  +\$0
- HY** walnut on cherry  +\$0
- LA** light ash  +\$0
- LBA** clear on ash  +\$0
- LBB** oak on ash  +\$0
- LBC** walnut on ash  +\$0
- LBD** dark brown walnut  +\$0
- LBE** medium red walnut  +\$0
- LBF** neutral twill  +\$0
- LBG** sarum twill  +\$0
- LBH** earthen twill  +\$0
- LBJ** graphite twill  +\$0
- LBK** pewter mesh  +\$0
- LBL** steel mesh  +\$0
- LBM** crisp linen  +\$0
- LBN** classic linen  +\$0
- LBP** casual linen  +\$0
- LBQ** white twill  +\$0
- LM** mahogany  +\$0
- LT** light tone  +\$0
- LU** soft white  +\$0
- MT** medium tone  +\$0
- WL** sandstone  +\$0
- WN** warm grey neutral  +\$0

# Straight Filler

CH430.

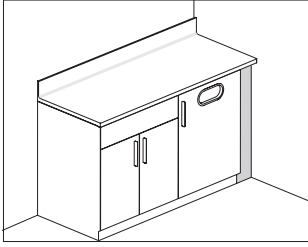

## Product Information

### Description

This 4"-wide component fills space in a run of cases, overheads, or towers. The straight filler fills the space between a run of base cabinets and a wall.

### Dimensions

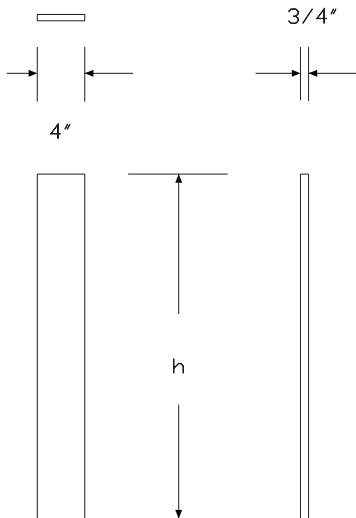

## Specification Information

### Step 1.

**CH430.**  A

### Step 2. Height

<b>190</b>	19"-high overhead case <input type="checkbox"/> A	+\$95
<b>20W</b>	wall-mounted base case <input type="checkbox"/> A	+\$95
<b>23S</b>	23"-high soffit <input type="checkbox"/> A	+\$100
<b>310</b>	31"-high overhead case <input type="checkbox"/> A	+\$110
<b>34T</b>	34"-high to-the-floor base case <input type="checkbox"/> A	+\$110
<b>35S</b>	35"-high soffit <input type="checkbox"/> A	+\$100
<b>36T</b>	36"-high to-the-floor base case <input type="checkbox"/> A	+\$110
<b>66T</b>	66"-high to-the-floor tower <input type="checkbox"/> A	+\$230
<b>66W</b>	66"-high wall-mounted tower <input type="checkbox"/> A	+\$180
<b>74T</b>	74"-high to-the-floor tower <input type="checkbox"/> A	+\$245
<b>74W</b>	74"-high wall-mounted tower <input type="checkbox"/> A	+\$210

### Step 3. Material

<b>L</b>	low-pressure laminate <input type="checkbox"/> A	+\$0
<b>H</b>	high-pressure laminate <input type="checkbox"/> A	+\$25

### Step 4. Grain Direction

*For 19"-high overhead case (190), wall-mounted base case (20W), 23"-high soffit (23S), 31"-high overhead case (310), 34"-high to-the-floor base case (34T), 35"-high soffit (35S), or 36"-high to-the-floor base case (36T)*

<b>HRG</b>	horizontal grain <input type="checkbox"/> A	+\$0
<b>VTG</b>	vertical grain <input type="checkbox"/> A	+\$0

*For 66"-high to-the-floor tower (66T), 66"-high wall-mounted tower (66W), 74"-high to-the-floor tower (74T), or 74"-high wall-mounted tower (74W)*

<b>VTG</b>	vertical grain <input type="checkbox"/> A	+\$0
------------	---	------

Mora™ Towers

# Straight Filler *continued*

Mora™ Towers

## Step 5. Finish

### For low-pressure laminate (L)

<b>76</b>	light brown walnut <input type="checkbox"/>	+\$0
<b>8Q</b>	folkstone grey <input type="checkbox"/>	+\$0
<b>91</b>	white <input type="checkbox"/>	+\$0
<b>98</b>	studio white <input type="checkbox"/>	+\$0
<b>CL</b>	cool grey neutral <input type="checkbox"/>	+\$0
<b>HM</b>	natural maple <input type="checkbox"/>	+\$0
<b>HP</b>	light anigre <input type="checkbox"/>	+\$0
<b>HX</b>	aged cherry <input type="checkbox"/>	+\$0
<b>HY</b>	walnut on cherry <input type="checkbox"/>	+\$0
<b>LA</b>	light ash <input type="checkbox"/>	+\$0
<b>LBA</b>	clear on ash <input type="checkbox"/>	+\$0
<b>LBB</b>	oak on ash <input type="checkbox"/>	+\$0
<b>LBC</b>	walnut on ash <input type="checkbox"/>	+\$0
<b>LBD</b>	dark brown walnut <input type="checkbox"/>	+\$0
<b>LBE</b>	medium red walnut <input type="checkbox"/>	+\$0
<b>LBF</b>	neutral twill <input type="checkbox"/>	+\$0
<b>LBG</b>	sarum twill <input type="checkbox"/>	+\$0
<b>LBH</b>	earthen twill <input type="checkbox"/>	+\$0
<b>LBJ</b>	graphite twill <input type="checkbox"/>	+\$0
<b>LBK</b>	pewter mesh <input type="checkbox"/>	+\$0
<b>LBL</b>	steel mesh <input type="checkbox"/>	+\$0
<b>LBM</b>	crisp linen <input type="checkbox"/>	+\$0
<b>LBN</b>	classic linen <input type="checkbox"/>	+\$0
<b>LBP</b>	casual linen <input type="checkbox"/>	+\$0
<b>LBQ</b>	white twill <input type="checkbox"/>	+\$0
<b>LBR</b>	phantom ecru <input type="checkbox"/>	+\$0
<b>LBS</b>	phantom cocoa <input type="checkbox"/>	+\$0
<b>LBU</b>	medium matte walnut <input type="checkbox"/>	+\$0
<b>LBV</b>	warm grey teak <input type="checkbox"/>	+\$0
<b>LU</b>	soft white <input type="checkbox"/>	+\$0
<b>WL</b>	sandstone <input type="checkbox"/>	+\$0
<b>WN</b>	warm grey neutral <input type="checkbox"/>	+\$0

### For high-pressure laminate (H)

<b>76</b>	light brown walnut <input type="checkbox"/>	+\$0
<b>8Q</b>	folkstone grey <input type="checkbox"/>	+\$0
<b>91</b>	white <input type="checkbox"/>	+\$0
<b>98</b>	studio white <input type="checkbox"/>	+\$0
<b>CL</b>	cool grey neutral <input type="checkbox"/>	+\$0
<b>HF</b>	inner tone light <input type="checkbox"/>	+\$0
<b>HM</b>	natural maple <input type="checkbox"/>	+\$0
<b>HP</b>	light anigre <input type="checkbox"/>	+\$0
<b>HT</b>	inner tone <input type="checkbox"/>	+\$0
<b>HX</b>	aged cherry <input type="checkbox"/>	+\$0

<b>HY</b>	walnut on cherry <input type="checkbox"/>	+\$0
<b>LA</b>	light ash <input type="checkbox"/>	+\$0
<b>LBA</b>	clear on ash <input type="checkbox"/>	+\$0
<b>LBB</b>	oak on ash <input type="checkbox"/>	+\$0
<b>LBC</b>	walnut on ash <input type="checkbox"/>	+\$0
<b>LBD</b>	dark brown walnut <input type="checkbox"/>	+\$0
<b>LBE</b>	medium red walnut <input type="checkbox"/>	+\$0
<b>LBF</b>	neutral twill <input type="checkbox"/>	+\$0
<b>LBG</b>	sarum twill <input type="checkbox"/>	+\$0
<b>LBH</b>	earthen twill <input type="checkbox"/>	+\$0
<b>LBJ</b>	graphite twill <input type="checkbox"/>	+\$0
<b>LBK</b>	pewter mesh <input type="checkbox"/>	+\$0
<b>LBL</b>	steel mesh <input type="checkbox"/>	+\$0
<b>LBM</b>	crisp linen <input type="checkbox"/>	+\$0
<b>LBN</b>	classic linen <input type="checkbox"/>	+\$0
<b>LBP</b>	casual linen <input type="checkbox"/>	+\$0
<b>LBQ</b>	white twill <input type="checkbox"/>	+\$0
<b>LBR</b>	phantom ecru <input type="checkbox"/>	+\$0
<b>LBS</b>	phantom cocoa <input type="checkbox"/>	+\$0
<b>LBU</b>	medium matte walnut <input type="checkbox"/>	+\$0
<b>LBV</b>	warm grey teak <input type="checkbox"/>	+\$0
<b>LM</b>	mahogany <input type="checkbox"/>	+\$0
<b>LT</b>	light tone <input type="checkbox"/>	+\$0
<b>LU</b>	soft white <input type="checkbox"/>	+\$0
<b>MT</b>	medium tone <input type="checkbox"/>	+\$0
<b>WL</b>	sandstone <input type="checkbox"/>	+\$0
<b>WN</b>	warm grey neutral <input type="checkbox"/>	+\$0



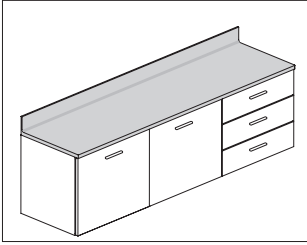

**Product Information**

**Description**

This Corian® work surface attaches to the top of 1 or more base cabinets or extends over the side of a base cabinet with an end panel support. It is available with integrated backsplash or without backsplash. Attachment hardware included.

**Notes**

Order the following products separately:

- Wall-mounted drawer or door base cabinets (CH200., CH210.)
- To-the-floor drawer or door base cabinets (CH220., CH230.)
- End panel (CH655.)

**Dimensions**

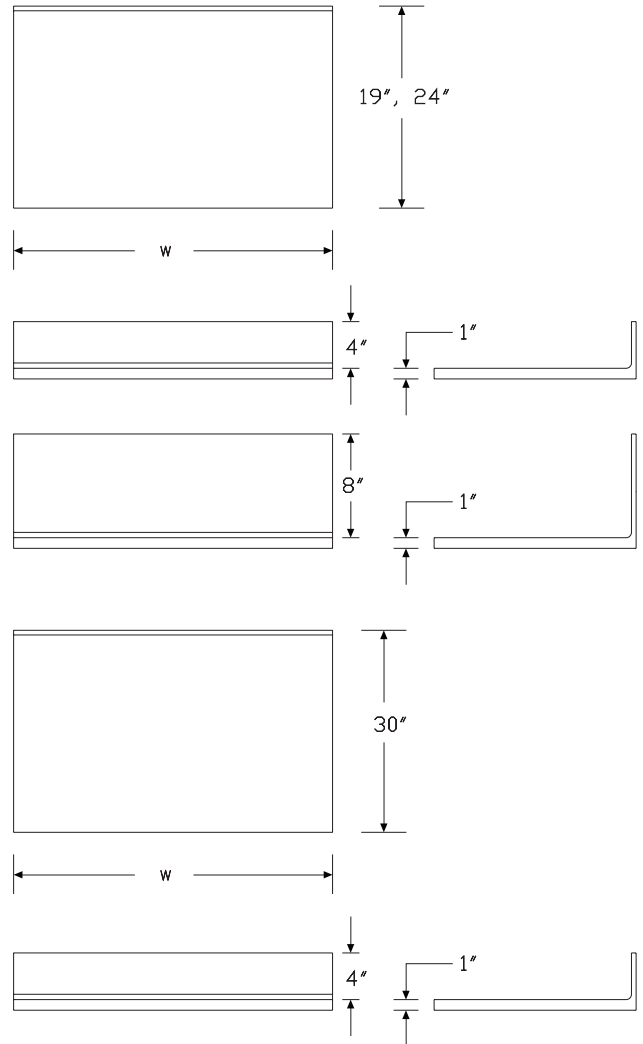

Mora™ Surfaces

# Corian Work Surface *continued*

Mora™ Surfaces

Specification Information		
Step 1.		
<b>CH600.</b>		
Step 2. Depth		
<b>19</b>	19" deep	+\$600
<b>24</b>	24" deep	+\$650
<b>30</b>	30" deep	+\$1200
Step 3. Width		
<b>18</b>	18" wide	+\$0
<b>24</b>	24" wide	+\$75
<b>30</b>	30" wide	+\$150
<b>36</b>	36" wide	+\$300
<b>42</b>	42" wide	+\$450
<b>48</b>	48" wide	+\$550
<b>54</b>	54" wide	+\$650
<b>60</b>	60" wide	+\$800
<b>66</b>	66" wide	+\$900
<b>72</b>	72" wide	+\$1050
Step 4. Backsplash		
<i>For 19" deep (19) or 24" deep (24)</i>		
<b>4</b>	4" high integrated	+\$0
<b>8</b>	8" high integrated	+\$300
<b>N</b>	no backsplash	-\$100
<i>For 30" deep (30)</i>		
<b>4</b>	4" high integrated	+\$0
<b>N</b>	no backsplash	-\$100
Step 5. Work Surface Finish		
<b>1S</b>	savannah	+\$170
<b>1U</b>	sahara	+\$35
<b>4I</b>	sandstone	+\$35
<b>58</b>	cameo white	+\$0
<b>CQ</b>	glacier white	+\$0
<b>CRT</b>	concrete	+\$300
<b>FWN</b>	fawn	+\$300
<b>OQ</b>	silt	+\$170
<b>PGY</b>	pearl gray	+\$300
<b>QB</b>	bisque	+\$0
<b>SNS</b>	serene sage	+\$300

# Corian Work Surface with Oval Sink

CH605.

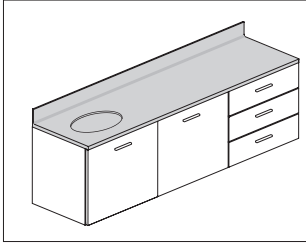

### Product Information

#### Description

This Corian® work surface with sink attaches to the top of 1 or more base cabinets or extends over the side of a base cabinet with an end panel support. Work surface comes with integrated backsplash. Attachment hardware included.

#### Notes

Surface is 1" thick.

If extended surface is desired, the extension must be on opposite end from sink.

Sink will always be centered over a sink cabinet.

Faucet must be field supplied.

Order the following products separately:

- Wall-mounted door base cabinets (CH210.)
- To-the-floor door base cabinets (CH230.)
- End panel (CH655.)

### Dimensions

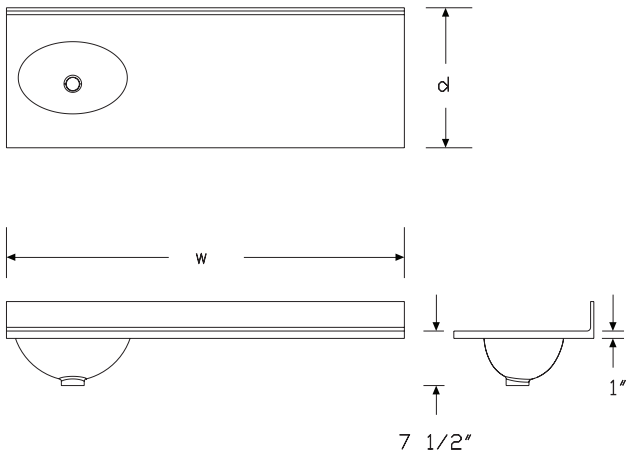

### Specification Information

#### Step 1.

**CH605.**

#### Step 2. Depth

<b>19</b>	19" deep	+\$1200
<b>24</b>	24" deep	+\$1250

#### Step 3. Width

<b>18</b>	18" wide	+\$0
<b>36</b>	36" wide	+\$300
<b>42</b>	42" wide	+\$450
<b>48</b>	48" wide	+\$550
<b>54</b>	54" wide	+\$650
<b>60</b>	60" wide	+\$800
<b>66</b>	66" wide	+\$900
<b>72</b>	72" wide	+\$1050

#### Step 4. Sink Cutout/Sink Cabinet Size & Location (sink centered above cabinets)

##### For 18" wide (18)

<b>SAO</b>	stand-alone 18" wide sink cabinet	+\$0
------------	-----------------------------------	------

##### For 36" wide (36), 42" wide (42), 48" wide (48), 54" wide (54), 60" wide (60), 66" wide (66), or 72" wide (72)

<b>18L</b>	18" sink cabinet on left	+\$0
<b>18R</b>	18" sink cabinet on right	+\$0

#### Step 5. Backsplash

<b>4</b>	4" high integrated	+\$0
<b>8</b>	8" high integrated	+\$300

#### Step 6. Work Surface Finish

<b>1S</b>	savannah	+\$170
<b>1U</b>	sahara	+\$35
<b>4I</b>	sandstone	+\$35
<b>58</b>	cameo white	+\$0
<b>CQ</b>	glacier white	+\$0
<b>CRT</b>	concrete	+\$300
<b>FWN</b>	fawn	+\$300
<b>OQ</b>	silt	+\$170
<b>PGY</b>	pearl gray	+\$300
<b>QB</b>	bisque	+\$0
<b>SNS</b>	serene sage	+\$300

Corian Work Surface with Oval Sink *continued*

---

Step 7. Sink Finish		
<b>CQ</b>	glacier white	+\$0

**Mora™ Surfaces**

# Corian Work Surface with Rectangular Sink

CH606.

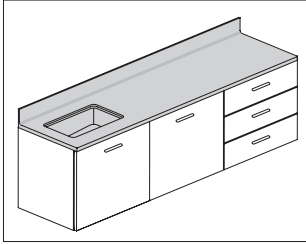

### Product Information

#### Description

This Corian® work surface with sink attaches to the top of 1 or more base cabinets or extends over the side of a base cabinet with an end panel support. Work surface comes with integrated backsplash. Attachment hardware included.

#### Notes

Surface is 1" thick.

If extended surface is desired, the extension must be on opposite end from sink.

Sink will always be centered over a sink cabinet.

Faucet must be field supplied.

Order the following products separately:

- Wall-mounted door base cabinets (CH210.)
- To-the-floor door base cabinets (CH230.)
- End panel (CH655.)

### Dimensions

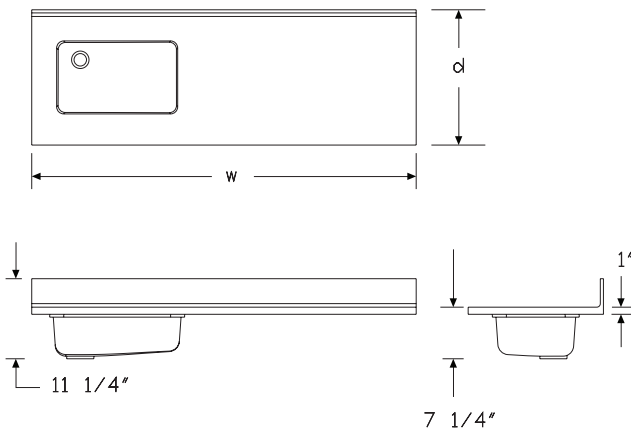

### Specification Information

#### Step 1.

**CH606.**

#### Step 2. Depth

<b>19</b>	19" deep	+\$1640
<b>24</b>	24" deep	+\$1690

#### Step 3. Width

<b>24</b>	24" wide	+\$0
<b>30</b>	30" wide	+\$75
<b>36</b>	36" wide	+\$225
<b>42</b>	42" wide	+\$375
<b>48</b>	48" wide	+\$475
<b>54</b>	54" wide	+\$575
<b>60</b>	60" wide	+\$725
<b>66</b>	66" wide	+\$825
<b>72</b>	72" wide	+\$975

#### Step 4. Sink Cutout/Sink Cabinet Size & Location (sink centered above cabinets)

*For 24" wide (24), 30" wide (30), or 36" wide (36)*

<b>SAR</b>	stand-alone 24", 30", 36" wide sink cabinet	+\$0
------------	---	------

*For 42" wide (42)*

<b>24L</b>	24" sink cabinet on left	+\$0
<b>24R</b>	24" sink cabinet on right	+\$0

*For 48" wide (48)*

<b>24L</b>	24" sink cabinet on left	+\$0
<b>24R</b>	24" sink cabinet on right	+\$0
<b>30L</b>	30" sink cabinet on left	+\$0
<b>30R</b>	30" sink cabinet on right	+\$0

*For 54" wide (54), 60" wide (60), 66" wide (66), or 72" wide (72)*

<b>24L</b>	24" sink cabinet on left	+\$0
<b>24R</b>	24" sink cabinet on right	+\$0
<b>30L</b>	30" sink cabinet on left	+\$0
<b>30R</b>	30" sink cabinet on right	+\$0
<b>36L</b>	36" sink cabinet on left	+\$0
<b>36R</b>	36" sink cabinet on right	+\$0

#### Step 5. Backsplash

<b>4</b>	4" high integrated	+\$0
<b>8</b>	8" high integrated	+\$300

Corian Work Surface with  
 Rectangular Sink *continued*

Mora™ Surfaces

Step 6. Work Surface Finish		
<b>1S</b>	savannah	+\$170
<b>1U</b>	sahara	+\$35
<b>4I</b>	sandstone	+\$35
<b>58</b>	cameo white	+\$0
<b>CQ</b>	glacier white	+\$0
<b>CRT</b>	concrete	+\$300
<b>FWN</b>	fawn	+\$300
<b>OQ</b>	silt	+\$170
<b>PGY</b>	pearl gray	+\$300
<b>QB</b>	bisque	+\$0
<b>SNS</b>	serene sage	+\$300
Step 7. Sink Finish		
<b>CRM</b>	crema	+\$0
<b>WFR</b>	white frost	+\$0

# Corian Work Surface with ADA Sink

CH607.

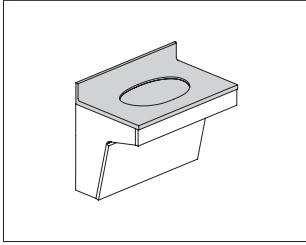

### Product Information

#### Description

This Corian® work surface with ADA sink attaches to the top of an ADA sink enclosure or spans multiple cases.

#### Notes

- Order ADA sink enclosure (CH240.) separately.
- Order wall-mounted or to-the-floor door cases separately.
- Sink will always be centered over a sink cabinet.
- Surface is 1" thick.
- For extended surface, the extension must be on opposite end from sink.
- Order end panel (CH655.) separately.
- Faucet must be field supplied.

#### Dimensions

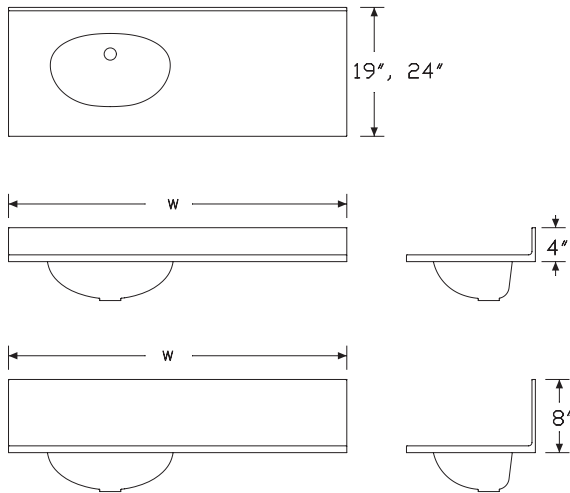

### Specification Information

#### Step 1.

**CH607.**

#### Step 2. Depth

<b>19</b>	19" deep	+\$1500
<b>24</b>	24" deep	+\$1600

#### Step 3. Width

<b>24</b>	24" wide	+\$75
<b>30</b>	30" wide	+\$0
<b>36</b>	36" wide	+\$150
<b>42</b>	42" wide	+\$300
<b>48</b>	48" wide	+\$450
<b>54</b>	54" wide	+\$600
<b>60</b>	60" wide	+\$700
<b>66</b>	66" wide	+\$820
<b>72</b>	72" wide	+\$950

#### Step 4. Sink Cutout/Sink Cabinet Size & Location

*For 24" wide (24), 30" wide (30), or 36" wide (36)*

<b>SAA</b>	standalone 24" or 30" wide ADA sink enclosure	+\$0
------------	---	------

*For 42" wide (42)*

<b>SAA</b>	stand-alone 42" wide ADA sink enclosure	+\$0
<b>24L</b>	24" ADA sink enclosure on left	+\$0
<b>24R</b>	24" ADA sink enclosure on right	+\$0
<b>30L</b>	30" ADA sink enclosure on left	+\$0
<b>30R</b>	30" ADA sink enclosure on right	+\$0

*For 48" wide (48)*

<b>SAA</b>	stand-alone 48" wide ADA sink enclosure	+\$0
<b>24L</b>	24" ADA sink enclosure on left	+\$0
<b>24R</b>	24" ADA sink enclosure on right	+\$0
<b>30L</b>	30" ADA sink enclosure on left	+\$0
<b>30R</b>	30" ADA sink enclosure on right	+\$0

*For 54" wide (54), 60" wide (60), 66" wide (66), or 72" wide (72)*

<b>24L</b>	24" ADA sink enclosure on left	+\$0
<b>24R</b>	24" ADA sink enclosure on right	+\$0
<b>30L</b>	30" ADA sink enclosure on left	+\$0
<b>30R</b>	30" ADA sink enclosure on right	+\$0
<b>36L</b>	36" ADA sink enclosure on left	+\$0
<b>36R</b>	36" ADA sink enclosure on right	+\$0
<b>42L</b>	42" ADA sink enclosure on left	+\$0
<b>42R</b>	42" ADA sink enclosure on right	+\$0

# Corian Work Surface with ADA Sink *continued*

Mora™ Surfaces

Step 5. Backsplash		
<b>4</b>	4" high integrated	+\$0
<b>8</b>	8" high integrated	+\$200

Step 6. Work Surface Finish		
<b>1S</b>	savannah	+\$170
<b>1U</b>	sahara	+\$35
<b>4I</b>	sandstone	+\$35
<b>58</b>	cameo white	+\$0
<b>CQ</b>	glacier white	+\$0
<b>CRT</b>	concrete	+\$300
<b>FWN</b>	fawn	+\$300
<b>OQ</b>	silt	+\$170
<b>PGY</b>	pearl gray	+\$300
<b>QB</b>	bisque	+\$0
<b>SNS</b>	serene sage	+\$300

Step 7. Sink Finish		
<b>QB</b>	bisque	+\$0
<b>CQ</b>	glacier white	+\$0



# Corian Work Surface with Work End

CH610.

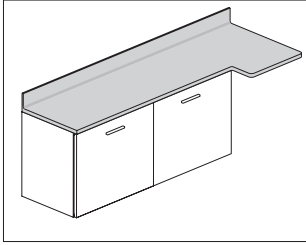

### Product Information

#### Description

This Corian® work surface with work end attaches to the top of 1 or more base cabinets. The work end allows for a quick touchdown space and can integrate technology. Work surface comes with integrated backsplash. Attachment hardware included.

#### Notes

Surface is 1" thick.

Work end adds 18" to width and is 26" deep.

When using in-line technology cabinet (CH720.) below, do not include its width when specifying the total width of cabinets below surface.

To use Flo® monitor arm, order Flo single screen monitor arm support with grommet mount (Y91171.GRO) separately. Grommet hole is field cut. See Planning Guide for more information.

Order the following products separately:

- Wall-mounted drawer or door base cabinets (CH200., CH210.)
- To-the-floor drawer or door base cabinets (CH220., CH230.)

#### Dimensions

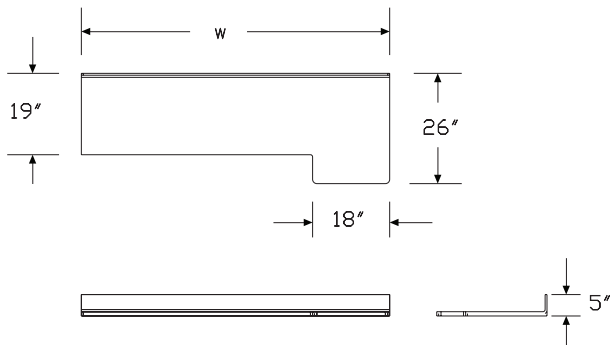

### Specification Information

#### Step 1.

**CH610.**

#### Step 2. Depth

<b>19</b>	19" deep	+\$1450
-----------	----------	---------

#### Step 3. Total Surface Width and Width of Cabinets Below Surface

<b>48</b>	48" wide surface, for use with 30" wide cabinets	+\$0
<b>54</b>	54" wide surface, for use with 36" wide cabinets	+\$150
<b>60</b>	60" wide surface, for use with 42" wide cabinets	+\$300
<b>66</b>	66" wide surface, for use with 48" wide cabinets	+\$450
<b>72</b>	72" wide surface, for use with 54" wide cabinets	+\$600
<b>78</b>	78" wide surface, for use with 60" wide cabinets	+\$750

#### Step 4. Work End/Extension Side

<b>L</b>	surface extension to left	+\$0
<b>R</b>	surface extension to right	+\$0

#### Step 5. Backsplash

<b>4</b>	4" high integrated	+\$0
----------	--------------------	------

#### Step 6. Work Surface Finish

<b>1S</b>	savannah	+\$210
<b>1U</b>	sahara	+\$45
<b>4I</b>	sandstone	+\$45
<b>58</b>	cameo white	+\$0
<b>CQ</b>	glacier white	+\$0
<b>CRT</b>	concrete	+\$350
<b>FWN</b>	fawn	+\$350
<b>OQ</b>	silt	+\$210
<b>PGY</b>	pearl gray	+\$350
<b>QB</b>	bisque	+\$0
<b>SNS</b>	serene sage	+\$350

Corian Work Surface with Work End and Oval Sink CH615.

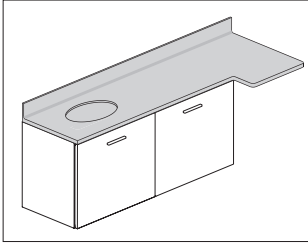

**Product Information**

**Description**

This Corian® work surface with work end and sink attaches to the top of 1 or more base cabinets. The work end allows for a quick touchdown space and can integrate technology. Work surface comes with integrated backsplash. Attachment hardware included.

**Notes**

- Surface is 1" thick.
- Work end adds 18" to width and is 26" deep.
- When sink is on the left, work end is on the right. When sink is on the right, work end is on the left.
- Sink will always be centered over a sink cabinet.
- Faucet must be field supplied.
- When using in-line technology cabinet (CH720.) below, do not include its width when specifying the total width of cabinets below surface.
- To use Flo® monitor arm, order cast grommet (Y92050.OI) for use with Flo monitor arm separately. Grommet hole is field cut. See Planning Guide for more information.
- Order the following products separately:
  - Wall-mounted drawer or door base cabinets (CH200., CH210.)
  - To-the-floor drawer or door base cabinets (CH220., CH230.)

**Dimensions**

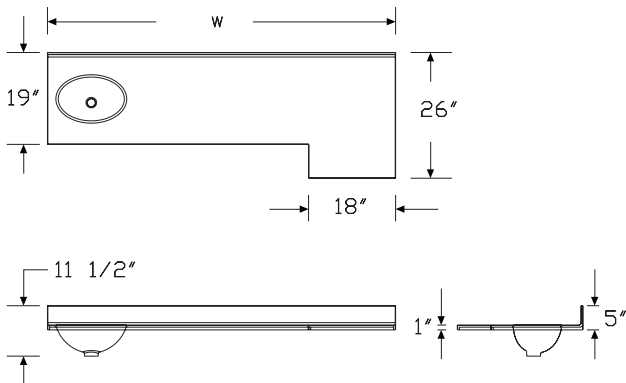

**Specification Information**

**Step 1.**

**CH615.**

**Step 2. Depth**

<b>19</b>	19" deep	+\$2250
-----------	----------	---------

**Step 3. Width**

<b>54</b>	54" wide surface, for use with 36" total run of cabinets	+\$0
<b>60</b>	60" wide surface, for use with 42" total run of cabinets	+\$150
<b>66</b>	66" wide surface, for use with 48" total run of cabinets	+\$300
<b>72</b>	72" wide surface, for use with 54" total run of cabinets	+\$450
<b>78</b>	78" wide surface, for use with 60" total run of cabinets	+\$600

**Step 4. Sink Cabinet Size Location**

<b>18L</b>	18" sink cabinet on left	+\$0
<b>18R</b>	18" sink cabinet on right	+\$0

**Step 5. Backsplash**

<b>4</b>	4" high integrated	+\$0
----------	--------------------	------

**Step 6. Work Surface Finish**

<b>1S</b>	savannah	+\$210
<b>1U</b>	sahara	+\$45
<b>4I</b>	sandstone	+\$45
<b>58</b>	cameo white	+\$0
<b>CQ</b>	glacier white	+\$0
<b>CRT</b>	concrete	+\$350
<b>FWN</b>	fawn	+\$350
<b>OQ</b>	silt	+\$210
<b>PGY</b>	pearl gray	+\$350
<b>QB</b>	bisque	+\$0
<b>SNS</b>	serene sage	+\$350

**Step 7. Sink Finish**

<b>CQ</b>	glacier white	+\$0
-----------	---------------	------

Mora™ Surfaces

# Corian Work Surface with Work End and Rectangular Sink

CH616.

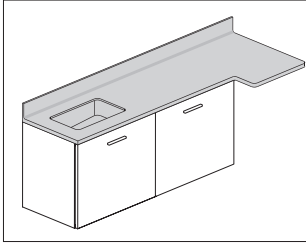

### Product Information

#### Description

This Corian® work surface with work end and sink attaches to the top of 1 or more base cabinets. The work end allows for a quick touchdown space and can integrate technology. Work surface comes with integrated backsplash. Attachment hardware included.

#### Notes

Surface is 1" thick.

Work end adds 18" to width and is 26" deep.

When sink is on the left, work end is on the right. When sink is on the right, work end is on the left.

Sink will always be centered over a sink cabinet.

Faucet must be field supplied.

When using in-line technology cabinet (CH720.) below, do not include its width when specifying the total width of cabinets below surface.

To use Flo® monitor arm, order cast grommet (Y92050.OI) for use with Flo monitor arm separately. Grommet hole is field cut. See Planning Guide for more information.

Order the following products separately:

- Wall-mounted drawer or door base cabinets (CH200., CH210.)
- To-the-floor drawer or door base cabinets (CH220., CH230.)

### Dimensions

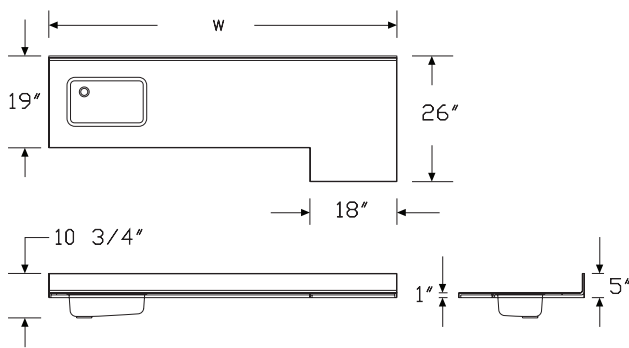

### Specification Information

#### Step 1.

**CH616.**

#### Step 2. Depth

<b>19</b>	19" deep	+\$2450
-----------	----------	---------

#### Step 3. Surface Width

<b>48</b>	48" wide surface, for use with 30" wide cabinets	+\$0
<b>54</b>	54" wide surface, for use with 36" total run of cabinets	+\$150
<b>60</b>	60" wide surface, for use with 42" total run of cabinets	+\$300
<b>66</b>	66" wide surface, for use with 48" total run of cabinets	+\$450
<b>72</b>	72" wide surface, for use with 54" total run of cabinets	+\$600
<b>78</b>	78" wide surface, for use with 60" total run of cabinets	+\$750

#### Step 4. Sink Cabinet Size Location

*For 48" wide surface, for use with 30" wide cabinets (48)*

<b>30L</b>	30" sink cabinet on left	+\$0
<b>30R</b>	30" sink cabinet on right	+\$0

*For 54" wide surface, for use with 36" total run of cabinets (54)*

<b>36L</b>	36" sink cabinet on left	+\$0
<b>36R</b>	36" sink cabinet on right	+\$0

*For 60" wide surface, for use with 42" total run of cabinets (60)*

<b>24L</b>	24" sink cabinet on left	+\$0
<b>24R</b>	24" sink cabinet on right	+\$0

*For 66" wide surface, for use with 48" total run of cabinets (66)*

<b>24L</b>	24" sink cabinet on left	+\$0
<b>24R</b>	24" sink cabinet on right	+\$0
<b>30L</b>	30" sink cabinet on left	+\$0
<b>30R</b>	30" sink cabinet on right	+\$0

*For 72" wide surface, for use with 54" total run of cabinets (72) or 78" wide surface, for use with 60" total run of cabinets (78)*

<b>24L</b>	24" sink cabinet on left	+\$0
<b>24R</b>	24" sink cabinet on right	+\$0
<b>30L</b>	30" sink cabinet on left	+\$0
<b>30R</b>	30" sink cabinet on right	+\$0
<b>36L</b>	36" sink cabinet on left	+\$0
<b>36R</b>	36" sink cabinet on right	+\$0

#### Step 5. Backsplash

<b>4</b>	4" high integrated	+\$0
----------	--------------------	------

Corian Work Surface with Work  
End and Rectangular Sink *continued*

Mora™ Surfaces

Step 6. Work Surface Finish		
<b>1S</b>	savannah	+\$210
<b>1U</b>	sahara	+\$45
<b>4I</b>	sandstone	+\$45
<b>58</b>	cameo white	+\$0
<b>CQ</b>	glacier white	+\$0
<b>CRT</b>	concrete	+\$350
<b>FWN</b>	fawn	+\$350
<b>OQ</b>	silt	+\$210
<b>PGY</b>	pearl gray	+\$350
<b>QB</b>	bisque	+\$0
<b>SNS</b>	serene sage	+\$350
Step 7. Sink Finish		
<b>WFR</b>	white frost	+\$0
<b>CRM</b>	crema	+\$0

# Sidesplash

CH618.

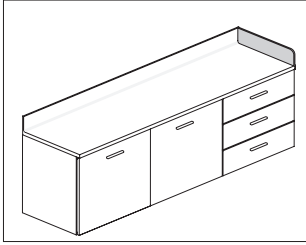

### Product Information

#### Description

This sidesplash attaches to a wall or a Mora™ System tower. Finish is Corian®. Attachment hardware not included.

#### Notes

It is recommended to seal the sidesplash attachment with silicone or caulk.

#### Dimensions

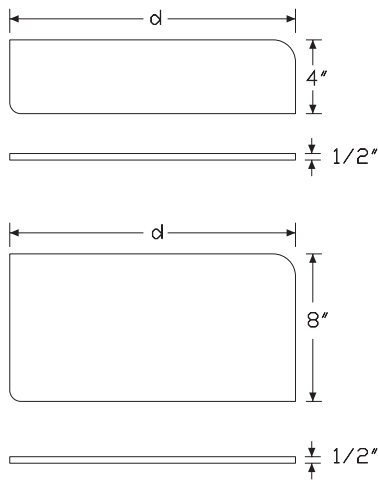

### Specification Information

#### Step 1.

**CH618.**

#### Step 2. Depth

<b>W19</b>	19" deep, wall	+\$130
<b>W24</b>	24" deep, wall	+\$140
<b>T19</b>	19" deep, tower	+\$130
<b>T24</b>	24" deep, tower	+\$140
<b>W30</b>	30" deep, wall	+\$160

#### Step 3. Height

*For 19" deep, wall (W19), 24" deep, wall (W24), 19" deep, tower (T19), or 24" deep, tower (T24)*

<b>4</b>	4" high	+\$0
<b>8</b>	8" high	+\$50

*For 30" deep, wall (W30)*

<b>4</b>	4" high	+\$0
----------	---------	------

#### Step 4. Placement

<b>L</b>	left	+\$0
<b>R</b>	right	+\$0

#### Step 5. Work Surface Finish

<b>1S</b>	savannah	+\$10
<b>1U</b>	sahara	+\$5
<b>4I</b>	sandstone	+\$5
<b>58</b>	cameo white	+\$0
<b>CQ</b>	glacier white	+\$0
<b>CRT</b>	concrete	+\$20
<b>FWN</b>	fawn	+\$20
<b>OQ</b>	silt	+\$10
<b>PGY</b>	pearl gray	+\$20
<b>QB</b>	bisque	+\$0
<b>SNS</b>	serene sage	+\$20

Mora™ Surfaces

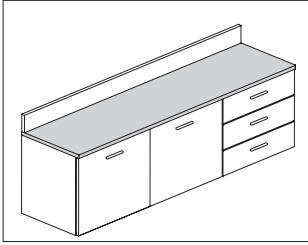

**Product Information**

**Description**

This HPL work surface attaches to the top of 1 or more base cabinets or extends over the side of a base cabinet with an end panel support. Attachment hardware included.

**Notes**

Surface is 1" thick.

Grain direction is horizontal for woodgrain finishes.

If sink is desired, the sink cutout must be field cut and sink and faucet must be field supplied.

Order the following products separately:

- Wall-mounted drawer or door base cabinets (CH200., CH210.)
- To-the-floor drawer or door base cabinets (CH220., CH230.)
- End panel (CH655.)
- HPL backsplash (CH650.)

**Dimensions**

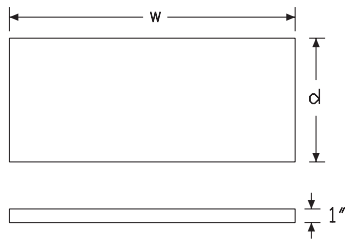

**Specification Information**

**Step 1.**

**CH620.**

**Step 2. Depth**

<b>19</b>	19" deep	+\$200
<b>24</b>	24" deep	+\$225
<b>30</b>	30" deep	+\$300

**Step 3. Width**

<b>18</b>	18" wide	+\$0
<b>24</b>	24" wide	+\$20
<b>30</b>	30" wide	+\$40
<b>36</b>	36" wide	+\$70
<b>42</b>	42" wide	+\$90
<b>48</b>	48" wide	+\$110
<b>54</b>	54" wide	+\$170
<b>60</b>	60" wide	+\$185
<b>66</b>	66" wide	+\$200
<b>72</b>	72" wide	+\$220

**Step 4. Finish**

<b>76</b>	light brown walnut	+\$0
<b>8Q</b>	folkstone grey	+\$0
<b>91</b>	white	+\$0
<b>98</b>	studio white	+\$0
<b>BU</b>	black umber	+\$0
<b>CL</b>	cool grey neutral	+\$0
<b>HF</b>	inner tone light	+\$0
<b>HM</b>	natural maple	+\$0
<b>HP</b>	light anigre	+\$0
<b>HT</b>	inner tone	+\$0
<b>HX</b>	aged cherry	+\$0
<b>HY</b>	walnut on cherry	+\$0
<b>LA</b>	light ash	+\$0
<b>LBA</b>	clear on ash	+\$0
<b>LBR</b>	phantom ecru	+\$0
<b>LBS</b>	phantom cocoa	+\$0
<b>LBV</b>	warm grey teak	+\$0
<b>LBU</b>	medium matte walnut	+\$0
<b>LBB</b>	oak on ash	+\$0
<b>LBC</b>	walnut on ash	+\$0
<b>LBD</b>	dark brown walnut	+\$0
<b>LBE</b>	medium red walnut	+\$0
<b>LBF</b>	neutral twill	+\$0
<b>LBG</b>	sarum twill	+\$0
<b>LBH</b>	earthen twill	+\$0

## HPL Work Surface *continued*

<b>LBJ</b>	graphite twill	+\$0	<b>LBQ</b>	white twill	+\$0
<b>LBK</b>	pewter mesh	+\$0	<b>LU</b>	soft white	+\$0
<b>LBL</b>	steel mesh	+\$0	<b>MT</b>	medium tone	+\$0
<b>LBM</b>	crisp linen	+\$0	<b>WL</b>	sandstone	+\$0
<b>LBN</b>	classic linen	+\$0	<b>WN</b>	warm grey neutral	+\$0
<b>LBP</b>	casual linen	+\$0			
<b>LBQ</b>	white twill	+\$0			
<b>LU</b>	soft white	+\$0			
<b>MT</b>	medium tone	+\$0			
<b>OL</b>	white oak (nonstandard)	+\$0			
<b>WL</b>	sandstone	+\$0			
<b>WN</b>	warm grey neutral	+\$0			

### Step 5. Edge Finish

<b>76</b>	light brown walnut	+\$0
<b>8Q</b>	folkstone grey	+\$0
<b>8Z</b>	neutral grey	+\$0
<b>91</b>	white	+\$0
<b>98</b>	studio white	+\$0
<b>BU</b>	black umber	+\$0
<b>CL</b>	cool grey neutral	+\$0
<b>HF</b>	inner tone light	+\$0
<b>HM</b>	natural maple	+\$0
<b>HP</b>	light anigre	+\$0
<b>HT</b>	inner tone	+\$0
<b>HX</b>	aged cherry	+\$0
<b>HY</b>	walnut on cherry	+\$0
<b>JB</b>	millwork cherry	+\$0
<b>LA</b>	light ash	+\$0
<b>LBA</b>	clear on ash	+\$0
<b>LBR</b>	phantom ecru	+\$0
<b>LBS</b>	phantom cocoa	+\$0
<b>LBV</b>	warm grey teak	+\$0
<b>LBU</b>	medium matte walnut	+\$0
<b>LBB</b>	oak on ash	+\$0
<b>LBC</b>	walnut on ash	+\$0
<b>LBD</b>	dark brown walnut	+\$0
<b>LBE</b>	medium red walnut	+\$0
<b>LBF</b>	neutral twill	+\$0
<b>LBG</b>	sarum twill	+\$0
<b>LBH</b>	earthen twill	+\$0
<b>LBJ</b>	graphite twill	+\$0
<b>LBK</b>	pewter mesh	+\$0
<b>LBL</b>	steel mesh	+\$0
<b>LBM</b>	crisp linen	+\$0
<b>LBN</b>	classic linen	+\$0
<b>LBP</b>	casual linen	+\$0

HPL Work Surface with Work End CH630.

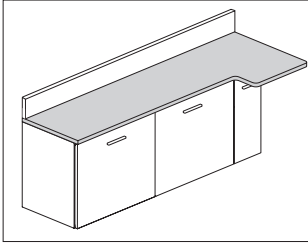

**Product Information**

**Description**

This HPL work surface with work end attaches to the top of 1 or more base cabinets. The work end allows for a quick touchdown space and can integrate technology.

**Notes**

Surface is 1" thick.

Work end adds 18" to width and is 26" deep.

When using in-line technology cabinet (CH720.) below, do not include its width when specifying the total width of cabinets below surface.

To use Flo® monitor arm attached to surface, order cast grommet (Y92050.01) for use with Flo monitor arm (Y91171.GRo) separately.

Grommet hole is field cut.

Order the following products separately:

- Wall-mounted drawer or door base cabinets (CH200., CH210.)
- To-the-floor drawer or door base cabinets (CH220., CH230.)
- (2) Surface wall attachment supports (CH646.)
- HPL backsplash (CH650.)

**Dimensions**

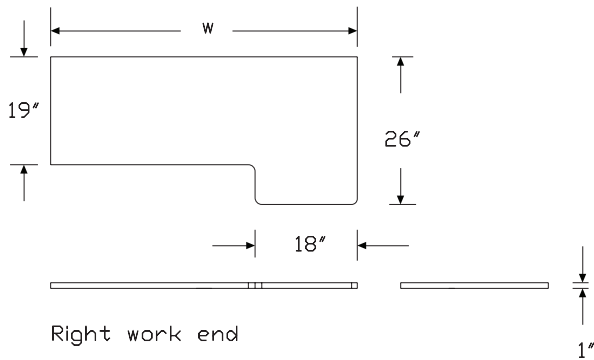

Left work end

**Specification Information**

**Step 1.**

**CH630.**

**Step 2. Depth**

<b>19</b>	19" deep	+\$330
-----------	----------	--------

**Step 3. Width**

<b>48</b>	48" wide surface, for use with 30" wide cabinets	+\$0
<b>54</b>	54" wide surface, for use with 36" wide cabinets	+\$30
<b>60</b>	60" wide surface, for use with 42" wide cabinets	+\$60
<b>66</b>	66" wide surface, for use with 48" wide cabinets	+\$90
<b>72</b>	72" wide surface, for use with 54" wide cabinets	+\$110
<b>78</b>	78" wide surface, for use with 60" wide cabinets	+\$135

**Step 4. Work End/Extension Side**

<b>L</b>	surface extension to left	+\$0
<b>R</b>	surface extension to right	+\$0

**Step 5. Top Finish**

<b>LBR</b>	phantom ecru	+\$0
<b>LBS</b>	phantom cocoa	+\$0
<b>LBV</b>	warm grey teak	+\$0
<b>76</b>	light brown walnut	+\$0
<b>8Q</b>	folkstone grey	+\$0
<b>91</b>	white	+\$0
<b>98</b>	studio white	+\$0
<b>CL</b>	cool grey neutral	+\$0
<b>HF</b>	inner tone light	+\$0
<b>HM</b>	natural maple	+\$0
<b>HP</b>	light anigre	+\$0
<b>HT</b>	inner tone	+\$0
<b>HX</b>	aged cherry	+\$0
<b>HY</b>	walnut on cherry	+\$0
<b>LA</b>	light ash	+\$0
<b>LBA</b>	clear on ash	+\$0
<b>LBB</b>	oak on ash	+\$0
<b>LBC</b>	walnut on ash	+\$0
<b>LBD</b>	dark brown walnut	+\$0
<b>LBE</b>	medium red walnut	+\$0
<b>LBF</b>	neutral twill	+\$0
<b>LBG</b>	sarum twill	+\$0
<b>LBH</b>	earthen twill	+\$0
<b>LBJ</b>	graphite twill	+\$0
<b>LBK</b>	pewter mesh	+\$0
<b>LBL</b>	steel mesh	+\$0
<b>LBM</b>	crisp linen	+\$0



# HPL Work Surface with Work End

continued

<b>LBN</b>	classic linen	+\$0	<b>LU</b>	soft white	+\$0
<b>LBP</b>	casual linen	+\$0	<b>MT</b>	medium tone	+\$0
<b>LBQ</b>	white twill	+\$0	<b>WL</b>	sandstone	+\$0
<b>LBU</b>	medium matte walnut	+\$0	<b>WN</b>	warm grey neutral	+\$0
<b>LM</b>	mahogany	+\$0			
<b>LT</b>	light tone	+\$0			
<b>LU</b>	soft white	+\$0			
<b>MT</b>	medium tone	+\$0			
<b>OL</b>	white oak (nonstandard)	+\$0			
<b>WL</b>	sandstone	+\$0			
<b>WN</b>	warm grey neutral	+\$0			

## Step 6. Edge

<b>76</b>	light brown walnut	+\$0
<b>8Q</b>	folkstone grey	+\$0
<b>8Z</b>	neutral grey	+\$0
<b>91</b>	white	+\$0
<b>98</b>	studio white	+\$0
<b>BU</b>	black umber	+\$0
<b>CL</b>	cool grey neutral	+\$0
<b>HF</b>	inner tone light	+\$0
<b>HM</b>	natural maple	+\$0
<b>HP</b>	light anigre	+\$0
<b>HT</b>	inner tone	+\$0
<b>HX</b>	aged cherry	+\$0
<b>HY</b>	walnut on cherry	+\$0
<b>JB</b>	millwork cherry	+\$0
<b>LA</b>	light ash	+\$0
<b>LBA</b>	clear on ash	+\$0
<b>LBR</b>	phantom ecru	+\$0
<b>LBS</b>	phantom cocoa	+\$0
<b>LBV</b>	warm grey teak	+\$0
<b>LBU</b>	medium matte walnut	+\$0
<b>LBB</b>	oak on ash	+\$0
<b>LBC</b>	walnut on ash	+\$0
<b>LBD</b>	dark brown walnut	+\$0
<b>LBE</b>	medium red walnut	+\$0
<b>LBF</b>	neutral twill	+\$0
<b>LBG</b>	sarum twill	+\$0
<b>LBH</b>	earthen twill	+\$0
<b>LBJ</b>	graphite twill	+\$0
<b>LBK</b>	pewter mesh	+\$0
<b>LBL</b>	steel mesh	+\$0
<b>LBM</b>	crisp linen	+\$0
<b>LBN</b>	classic linen	+\$0
<b>LBP</b>	casual linen	+\$0
<b>LBQ</b>	white twill	+\$0

Surface Wall Attachment Support CH646.

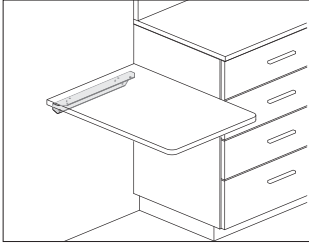

**Product Information**

**Description**  
This bracket attaches to a wall to support a work surface with work end, peninsula, or seated height work surface.

**Dimensions**

**Specification Information**

**Step 1.**  
**CH646.** \$70

Mora™ Surfaces

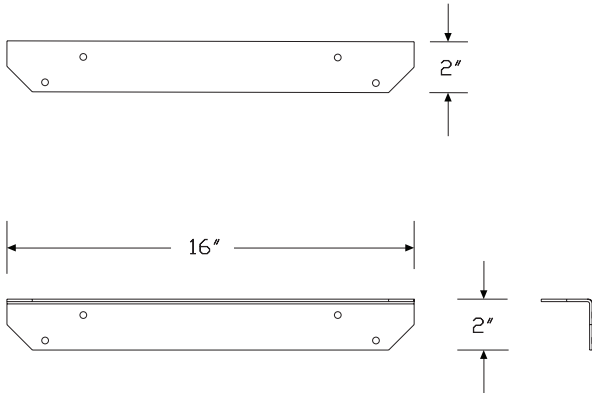

# HPL Backsplash

CH650.

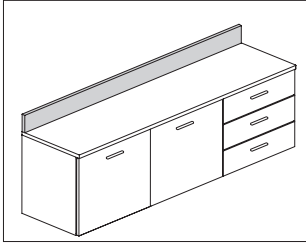

### Product Information

#### Description

This HPL backsplash sits on top of the HPL work surface.

#### Notes

Backsplash is 1" thick.

Backsplash edges must be silicone sealed in the field.

Order HPL work surface (CH620.) or HPL work surface with work end (CH630.) separately.

#### Dimensions

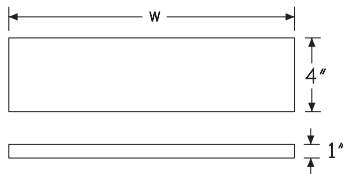

### Specification Information

#### Step 1.

**CH650.**

#### Step 2. Height

<b>4</b>	4" high	+\$120
----------	---------	--------

#### Step 3. Width

<b>18</b>	18" wide	+\$0
<b>24</b>	24" wide	+\$30
<b>30</b>	30" wide	+\$50
<b>36</b>	36" wide	+\$65
<b>42</b>	42" wide	+\$80
<b>48</b>	48" wide	+\$95
<b>54</b>	54" wide	+\$130
<b>60</b>	60" wide	+\$145
<b>66</b>	66" wide	+\$160
<b>72</b>	72" wide	+\$175

#### Step 4. Finish

<b>76</b>	light brown walnut	+\$0
<b>8Q</b>	folkstone grey	+\$0
<b>91</b>	white	+\$0
<b>98</b>	studio white	+\$0
<b>CL</b>	cool grey neutral	+\$0
<b>HF</b>	inner tone light	+\$0
<b>HM</b>	natural maple	+\$0
<b>HP</b>	light anigre	+\$0
<b>HT</b>	inner tone	+\$0
<b>HX</b>	aged cherry	+\$0
<b>HY</b>	walnut on cherry	+\$0
<b>LA</b>	light ash	+\$0
<b>LBA</b>	clear on ash	+\$0
<b>LBB</b>	oak on ash	+\$0
<b>LBC</b>	walnut on ash	+\$0
<b>LBD</b>	dark brown walnut	+\$0
<b>LBE</b>	medium red walnut	+\$0
<b>LBF</b>	neutral twill	+\$0
<b>LBG</b>	sarum twill	+\$0
<b>LBH</b>	earthen twill	+\$0
<b>LBJ</b>	graphite twill	+\$0
<b>LBK</b>	pewter mesh	+\$0
<b>LBL</b>	steel mesh	+\$0
<b>LBM</b>	crisp linen	+\$0
<b>LBN</b>	classic linen	+\$0
<b>LBP</b>	casual linen	+\$0
<b>LBQ</b>	white twill	+\$0

Mora™ Surfaces

# HPL Backsplash *continued*

<b>LBR</b>	phantom ecru	+\$0	<b>MT</b>	medium tone	+\$0
<b>LBS</b>	phantom cocoa	+\$0	<b>WL</b>	sandstone	+\$0
<b>LBU</b>	medium matte walnut	+\$0	<b>WN</b>	warm grey neutral	+\$0
<b>LBV</b>	warm grey teak	+\$0			
<b>LM</b>	mahogany	+\$0			
<b>LT</b>	light tone	+\$0			
<b>LU</b>	soft white	+\$0			
<b>MT</b>	medium tone	+\$0			
<b>WL</b>	sandstone	+\$0			
<b>WN</b>	warm grey neutral	+\$0			

## Step 5. Edge Finish

Mora™ Surfaces

<b>76</b>	light brown walnut	+\$0
<b>8Q</b>	folkstone grey	+\$0
<b>8Z</b>	neutral grey	+\$0
<b>91</b>	white	+\$0
<b>98</b>	studio white	+\$0
<b>BU</b>	black umber	+\$0
<b>CL</b>	cool grey neutral	+\$0
<b>HF</b>	inner tone light	+\$0
<b>HM</b>	natural maple	+\$0
<b>HP</b>	light anigre	+\$0
<b>HT</b>	inner tone	+\$0
<b>HX</b>	aged cherry	+\$0
<b>HY</b>	walnut on cherry	+\$0
<b>JB</b>	millwork cherry	+\$0
<b>LA</b>	light ash	+\$0
<b>LBA</b>	clear on ash	+\$0
<b>LBR</b>	phantom ecru	+\$0
<b>LBS</b>	phantom cocoa	+\$0
<b>LBV</b>	warm grey teak	+\$0
<b>LBU</b>	medium matte walnut	+\$0
<b>LBB</b>	oak on ash	+\$0
<b>LBC</b>	walnut on ash	+\$0
<b>LBD</b>	dark brown walnut	+\$0
<b>LBE</b>	medium red walnut	+\$0
<b>LBF</b>	neutral twill	+\$0
<b>LBG</b>	sarum twill	+\$0
<b>LBH</b>	earthen twill	+\$0
<b>LBJ</b>	graphite twill	+\$0
<b>LBK</b>	pewter mesh	+\$0
<b>LBL</b>	steel mesh	+\$0
<b>LBM</b>	crisp linen	+\$0
<b>LBN</b>	classic linen	+\$0
<b>LBP</b>	casual linen	+\$0
<b>LBQ</b>	white twill	+\$0
<b>LU</b>	soft white	+\$0

# End Panel

CH655.

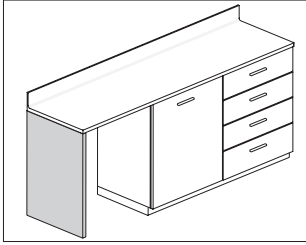

### Product Information

#### Description

This laminate panel supports an extended work surface. The panel has one 2" adjustable glide to level the surface above an uneven floor. Attachment hardware sold separately.

#### Notes

Order the following products separately:

- Corian® work surface (CH600.)
- Corian work surface with sink (CH605., CH606., CH607)
- HPL work surface (CH620.)
- (2) Surface wall attachment supports (CH646.). See planning guide for further instructions.

#### Dimensions

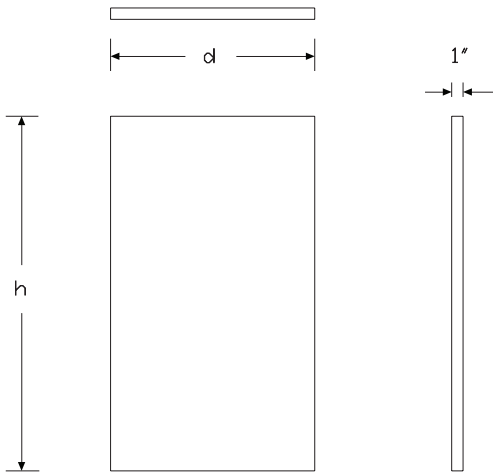

### Specification Information

#### Step 1.

**CH655.**

#### Step 2. Height

<b>34</b>	34" high	+\$220
<b>36</b>	36" high	+\$225

#### Step 3. Depth of Worksurface

<b>19</b>	19" deep	+\$0
<b>24</b>	24" deep	+\$20
<b>30</b>	30" deep	+\$30

#### Step 4. Material

<b>H</b>	high-pressure laminate	+\$0
----------	------------------------	------

#### Step 5. Grain Direction

<b>HRG</b>	horizontal grain	+\$0
<b>VTG</b>	vertical grain	+\$0

#### Step 6. Finish

<b>76</b>	light brown walnut	+\$0
<b>8Q</b>	folkstone grey	+\$0
<b>91</b>	white	+\$0
<b>98</b>	studio white	+\$0
<b>CL</b>	cool grey neutral	+\$0
<b>HF</b>	inner tone light	+\$0
<b>HM</b>	natural maple	+\$0
<b>HP</b>	light anigre	+\$0
<b>HT</b>	inner tone	+\$0
<b>HX</b>	aged cherry	+\$0
<b>HY</b>	walnut on cherry	+\$0
<b>LA</b>	light ash	+\$0
<b>LBA</b>	clear on ash	+\$0
<b>LBR</b>	phantom ecru	+\$0
<b>LBS</b>	phantom cocoa	+\$0
<b>LBV</b>	warm grey teak	+\$0
<b>LBU</b>	medium matte walnut	+\$0
<b>LBB</b>	oak on ash	+\$0
<b>LBC</b>	walnut on ash	+\$0
<b>LBD</b>	dark brown walnut	+\$0
<b>LBE</b>	medium red walnut	+\$0
<b>LBF</b>	neutral twill	+\$0
<b>LBG</b>	sarum twill	+\$0
<b>LBH</b>	earthen twill	+\$0
<b>LBJ</b>	graphite twill	+\$0
<b>LBK</b>	pewter mesh	+\$0

## End Panel *continued*

<b>LBL</b>	steel mesh	+\$0
<b>LBM</b>	crisp linen	+\$0
<b>LBN</b>	classic linen	+\$0
<b>LBP</b>	casual linen	+\$0
<b>LBQ</b>	white twill	+\$0
<b>LM</b>	mahogany	+\$0
<b>LT</b>	light tone	+\$0
<b>LU</b>	soft white	+\$0
<b>MT</b>	medium tone	+\$0
<b>OL</b>	white oak (nonstandard)	+\$0
<b>WL</b>	sandstone	+\$0
<b>WN</b>	warm grey neutral	+\$0

**Mora™ Surfaces**

# Cantilever

CH660.

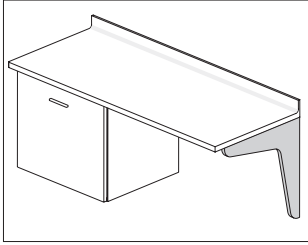

### Product Information

#### Description

This cantilever attaches to an architectural wall to support a work surface. Attachment hardware not included.

#### Notes

Order the following surfaces separately:

- Corian® work surface (CH600.)
- Corian work surface with sink (CH605., CH606.)
- HPL work surface (CH620.)
- Surface wall attachment support (CH646.)

#### Dimensions

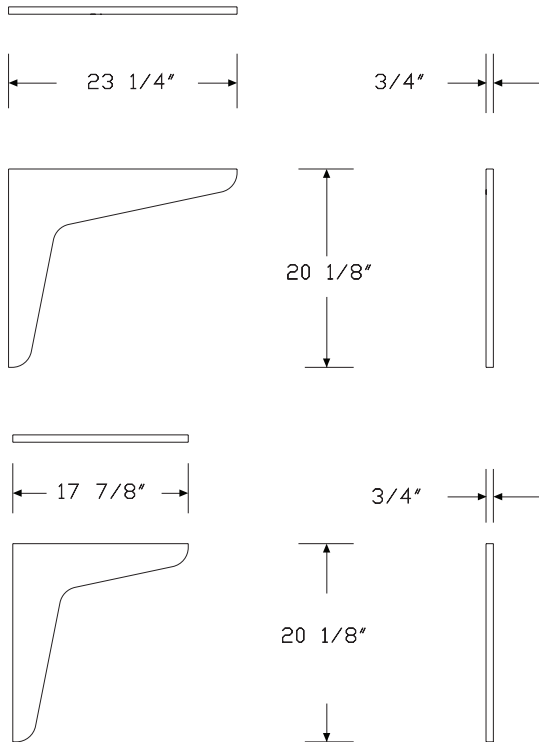

### Specification Information

#### Step 1.

**CH660.** [A]

#### Step 2. Depth of Worksurface

<b>19</b>	19" deep [A]	+\$165
<b>24</b>	24" deep [A]	+\$185

#### Step 3. Material

<b>H</b>	high-pressure laminate [A]	+\$75
<b>L</b>	low-pressure laminate [A]	+\$0

#### Step 4. Grain Direction

<b>HRG</b>	horizontal grain [A]	+\$0
<b>VTG</b>	vertical grain [A]	+\$0

#### Step 5. Finish

#### For low-pressure laminate (L)

<b>76</b>	light brown walnut [A]	+\$0
<b>8Q</b>	folkstone grey [A]	+\$0
<b>91</b>	white [A]	+\$0
<b>98</b>	studio white [A]	+\$0
<b>CL</b>	cool grey neutral [A]	+\$0
<b>HM</b>	natural maple [A]	+\$0
<b>HP</b>	light anigre [A]	+\$0
<b>HX</b>	aged cherry [A]	+\$0
<b>HY</b>	walnut on cherry [A]	+\$0
<b>LA</b>	light ash [A]	+\$0
<b>LBA</b>	clear on ash [A]	+\$0
<b>LBB</b>	oak on ash [A]	+\$0
<b>LBC</b>	walnut on ash [A]	+\$0
<b>LBD</b>	dark brown walnut [A]	+\$0
<b>LBE</b>	medium red walnut [A]	+\$0
<b>LBF</b>	neutral twill [A]	+\$0
<b>LBG</b>	sarum twill [A]	+\$0
<b>LBH</b>	earthen twill [A]	+\$0
<b>LBJ</b>	graphite twill [A]	+\$0
<b>LBK</b>	pewter mesh [A]	+\$0
<b>LBL</b>	steel mesh [A]	+\$0
<b>LBM</b>	crisp linen [A]	+\$0
<b>LBN</b>	classic linen [A]	+\$0
<b>LBP</b>	casual linen [A]	+\$0
<b>LBQ</b>	white twill [A]	+\$0
<b>LU</b>	soft white [A]	+\$0
<b>WL</b>	sandstone [A]	+\$0
<b>WN</b>	warm grey neutral [A]	+\$0

# Cantilever *continued*

Mora™ Surfaces

*For high-pressure laminate (H)*

<b>76</b>	light brown walnut <input type="checkbox"/> <b>A</b>	+\$0
<b>8Q</b>	folkstone grey <input type="checkbox"/> <b>A</b>	+\$0
<b>91</b>	white <input type="checkbox"/> <b>A</b>	+\$0
<b>98</b>	studio white <input type="checkbox"/> <b>A</b>	+\$0
<b>CL</b>	cool grey neutral <input type="checkbox"/> <b>A</b>	+\$0
<b>HF</b>	inner tone light <input type="checkbox"/> <b>A</b>	+\$0
<b>HM</b>	natural maple <input type="checkbox"/> <b>A</b>	+\$0
<b>HP</b>	light anigre <input type="checkbox"/> <b>A</b>	+\$0
<b>HT</b>	inner tone <input type="checkbox"/> <b>A</b>	+\$0
<b>HX</b>	aged cherry <input type="checkbox"/> <b>A</b>	+\$0
<b>HY</b>	walnut on cherry <input type="checkbox"/> <b>A</b>	+\$0
<b>LA</b>	light ash <input type="checkbox"/> <b>A</b>	+\$0
<b>LBA</b>	clear on ash <input type="checkbox"/> <b>A</b>	+\$0
<b>LBB</b>	oak on ash <input type="checkbox"/> <b>A</b>	+\$0
<b>LBC</b>	walnut on ash <input type="checkbox"/> <b>A</b>	+\$0
<b>LBD</b>	dark brown walnut <input type="checkbox"/> <b>A</b>	+\$0
<b>LBE</b>	medium red walnut <input type="checkbox"/> <b>A</b>	+\$0
<b>LBF</b>	neutral twill <input type="checkbox"/> <b>A</b>	+\$0
<b>LBG</b>	sarum twill <input type="checkbox"/> <b>A</b>	+\$0
<b>LBH</b>	earthen twill <input type="checkbox"/> <b>A</b>	+\$0
<b>LBJ</b>	graphite twill <input type="checkbox"/> <b>A</b>	+\$0
<b>LBK</b>	pewter mesh <input type="checkbox"/> <b>A</b>	+\$0
<b>LBL</b>	steel mesh <input type="checkbox"/> <b>A</b>	+\$0
<b>LBM</b>	crisp linen <input type="checkbox"/> <b>A</b>	+\$0
<b>LBN</b>	classic linen <input type="checkbox"/> <b>A</b>	+\$0
<b>LBP</b>	casual linen <input type="checkbox"/> <b>A</b>	+\$0
<b>LBQ</b>	white twill <input type="checkbox"/> <b>A</b>	+\$0
<b>LM</b>	mahogany <input type="checkbox"/> <b>A</b>	+\$0
<b>LT</b>	light tone <input type="checkbox"/> <b>A</b>	+\$0
<b>LU</b>	soft white <input type="checkbox"/> <b>A</b>	+\$0
<b>MT</b>	medium tone <input type="checkbox"/> <b>A</b>	+\$0
<b>N1</b>	grey nebula (nonstandard) <input type="checkbox"/> <b>A</b>	+\$0
<b>WL</b>	sandstone <input type="checkbox"/> <b>A</b>	+\$0
<b>WN</b>	warm grey neutral <input type="checkbox"/> <b>A</b>	+\$0
<b>ZZ</b>	open line laminate (nonstandard) <input type="checkbox"/> <b>A</b>	+\$20



# Backdrop Panel

CH670.

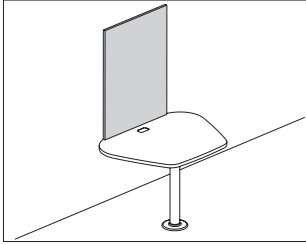

### Product Information

#### Description

This panel attaches above a work surface or technology cabinet to provide a home for technology. Attachment hardware included.

#### Notes

Variety of heights allow panel to align with top of all overhead cabinets and towers, including sloped tops. See Planning Guide for height alignment.

#### Dimensions

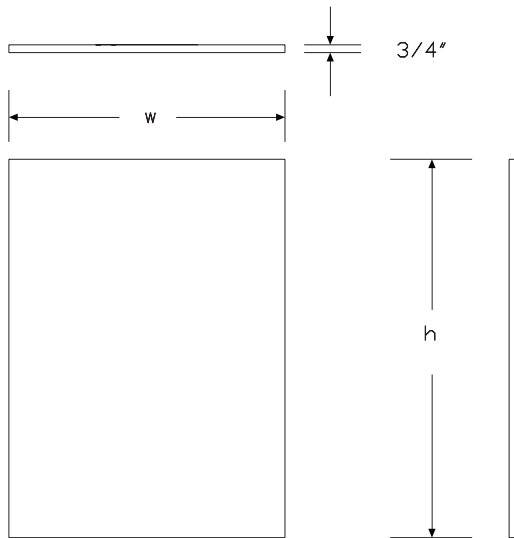

### Specification Information

#### Step 1.

**CH670.**

#### Step 2. Height

11	11" high	+\$335
15	15" high	+\$340
19	19" high	+\$345
22	22" high	+\$450
26	26" high	+\$355
29	29" high	+\$360
30	30" high	+\$362
32	32" high	+\$368
33	33" high	+\$370
37	37" high	+\$378
38	38" high	+\$380
45	45" high	+\$400

#### Step 3. Width

24	24" wide	-\$50
27	27" wide	-\$47
30	30" wide	-\$45
36	36" wide	-\$30
42	42" wide	-\$15
48	48" wide	+\$0
54	54" wide	+\$15
60	60" wide	+\$30
66	66" wide	+\$40
72	72" wide	+\$50

#### Step 4. Material

L	low-pressure laminate	+\$0
H	high-pressure laminate	+\$150

#### Step 5. Grain Direction

For 24" wide (24), 27" wide (27), 30" wide (30), 36" wide (36), 42" wide (42), 48" wide (48), 54" wide (54), or 60" wide (60)

HRG	horizontal grain	+\$0
VTG	vertical grain	+\$0

For 66" wide (66) or 72" wide (72)

HRG	horizontal grain	+\$0
-----	------------------	------

# Backdrop Panel *continued*

Mora™ Surfaces

---

Step 6. Finish

---

*For low-pressure laminate (L)*

---

<b>76</b>	light brown walnut	+\$0
<b>8Q</b>	folkstone grey	+\$0
<b>91</b>	white	+\$0
<b>98</b>	studio white	+\$0
<b>CL</b>	cool grey neutral	+\$0
<b>HM</b>	natural maple	+\$0
<b>HP</b>	light anigre	+\$0
<b>HX</b>	aged cherry	+\$0
<b>HY</b>	walnut on cherry	+\$0
<b>LA</b>	light ash	+\$0
<b>LBA</b>	clear on ash	+\$0
<b>LBR</b>	phantom ecru	+\$0
<b>LBS</b>	phantom cocoa	+\$0
<b>LBU</b>	medium matte walnut	+\$0
<b>LBV</b>	warm grey teak	+\$0
<b>LBB</b>	oak on ash	+\$0
<b>LBC</b>	walnut on ash	+\$0
<b>LBD</b>	dark brown walnut	+\$0
<b>LBE</b>	medium red walnut	+\$0
<b>LBF</b>	neutral twill	+\$0
<b>LBG</b>	sarum twill	+\$0
<b>LBH</b>	earthen twill	+\$0
<b>LBJ</b>	graphite twill	+\$0
<b>LBK</b>	pewter mesh	+\$0
<b>LBL</b>	steel mesh	+\$0
<b>LBM</b>	crisp linen	+\$0
<b>LBN</b>	classic linen	+\$0
<b>LBP</b>	casual linen	+\$0
<b>LBQ</b>	white twill	+\$0
<b>LU</b>	soft white	+\$0
<b>WL</b>	sandstone	+\$0
<b>WN</b>	warm grey neutral	+\$0

---

*For high-pressure laminate (H)*

---

<b>76</b>	light brown walnut	+\$0
<b>8Q</b>	folkstone grey	+\$0
<b>91</b>	white	+\$0
<b>98</b>	studio white	+\$0
<b>BU</b>	black umber	+\$0
<b>CL</b>	cool grey neutral	+\$0
<b>HF</b>	inner tone light	+\$0
<b>HM</b>	natural maple	+\$0
<b>HP</b>	light anigre	+\$0
<b>HT</b>	inner tone	+\$0

<b>HX</b>	aged cherry	+\$0
<b>HY</b>	walnut on cherry	+\$0
<b>LA</b>	light ash	+\$0
<b>LBA</b>	clear on ash	+\$0
<b>LBR</b>	phantom ecru	+\$0
<b>LBS</b>	phantom cocoa	+\$0
<b>LBV</b>	warm grey teak	+\$0
<b>LBU</b>	medium matte walnut	+\$0
<b>LBB</b>	oak on ash	+\$0
<b>LBC</b>	walnut on ash	+\$0
<b>LBD</b>	dark brown walnut	+\$0
<b>LBE</b>	medium red walnut	+\$0
<b>LBF</b>	neutral twill	+\$0
<b>LBG</b>	sarum twill	+\$0
<b>LBH</b>	earthen twill	+\$0
<b>LBJ</b>	graphite twill	+\$0
<b>LBK</b>	pewter mesh	+\$0
<b>LBL</b>	steel mesh	+\$0
<b>LBM</b>	crisp linen	+\$0
<b>LBN</b>	classic linen	+\$0
<b>LBP</b>	casual linen	+\$0
<b>LBQ</b>	white twill	+\$0
<b>LM</b>	mahogany	+\$0
<b>LT</b>	light tone	+\$0
<b>LU</b>	soft white	+\$0
<b>MT</b>	medium tone	+\$0
<b>WL</b>	sandstone	+\$0
<b>WN</b>	warm grey neutral	+\$0

# Floating Shelf

CH675.

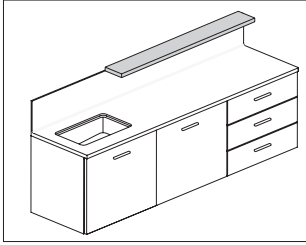

### Product Information

#### Description

This HPL shelf attaches directly to a wall or backdrop panel. Attachment hardware included.

#### Notes

Shelf is 1" thick.

Grain direction is always horizontal.

#### Dimensions

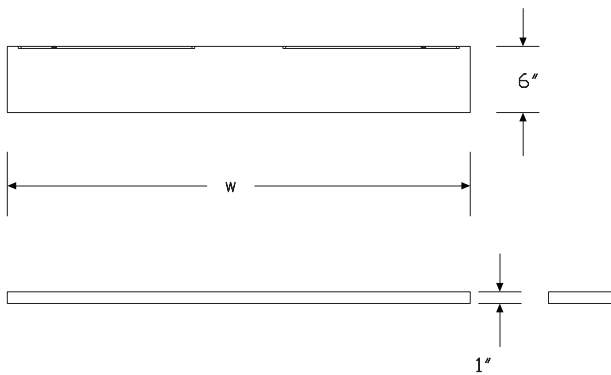

### Specification Information

#### Step 1.

**CH675.**

#### Step 2. Width

24	24" wide	+\$275
30	30" wide	+\$300
36	36" wide	+\$325
42	42" wide	+\$350
48	48" wide	+\$375
54	54" wide	+\$400
60	60" wide	+\$425
66	66" wide	+\$450
72	72" wide	+\$475

#### Step 3. Finish

<b>LBR</b>	phantom ecru	+\$0
<b>LBS</b>	phantom cocoa	+\$0
<b>LBV</b>	warm grey teak	+\$0
<b>76</b>	light brown walnut	+\$0
<b>8Q</b>	folkstone grey	+\$0
<b>91</b>	white	+\$0
<b>98</b>	studio white	+\$0
<b>CL</b>	cool grey neutral	+\$0
<b>HF</b>	inner tone light	+\$0
<b>HM</b>	natural maple	+\$0
<b>HP</b>	light anigre	+\$0
<b>HT</b>	inner tone	+\$0
<b>HX</b>	aged cherry	+\$0
<b>HY</b>	walnut on cherry	+\$0
<b>LA</b>	light ash	+\$0
<b>LBA</b>	clear on ash	+\$0
<b>LBB</b>	oak on ash	+\$0
<b>LBC</b>	walnut on ash	+\$0
<b>LBD</b>	dark brown walnut	+\$0
<b>LBE</b>	medium red walnut	+\$0
<b>LBF</b>	neutral twill	+\$0
<b>LBG</b>	sarum twill	+\$0
<b>LBH</b>	earthen twill	+\$0
<b>LBJ</b>	graphite twill	+\$0
<b>LBK</b>	pewter mesh	+\$0
<b>LBL</b>	steel mesh	+\$0
<b>LBM</b>	crisp linen	+\$0
<b>LBN</b>	classic linen	+\$0
<b>LBP</b>	casual linen	+\$0
<b>LBQ</b>	white twill	+\$0
<b>LBU</b>	medium matte walnut	+\$0

Mora™ Surfaces

# Floating Shelf *continued*

<b>LM</b>	mahogany	+\$0	<b>WN</b>	warm grey neutral	+\$0
<b>LT</b>	light tone	+\$0			
<b>LU</b>	soft white	+\$0			
<b>MT</b>	medium tone	+\$0			
<b>OL</b>	white oak (nonstandard)	+\$0			
<b>WL</b>	sandstone	+\$0			
<b>WN</b>	warm grey neutral	+\$0			
<b>ZZ</b>	open line laminate (nonstandard)	+\$20			

## Step 4. Edge Finish

Mora™ Surfaces

<b>LBR</b>	phantom ecru	+\$0
<b>LBS</b>	phantom cocoa	+\$0
<b>LBV</b>	warm grey teak	+\$0
<b>76</b>	light brown walnut	+\$0
<b>8Q</b>	folkstone grey	+\$0
<b>8Z</b>	neutral grey	+\$0
<b>91</b>	white	+\$0
<b>98</b>	studio white	+\$0
<b>BU</b>	black umber	+\$0
<b>CL</b>	cool grey neutral	+\$0
<b>HF</b>	inner tone light	+\$0
<b>HM</b>	natural maple	+\$0
<b>HP</b>	light anigre	+\$0
<b>HT</b>	inner tone	+\$0
<b>HX</b>	aged cherry	+\$0
<b>HY</b>	walnut on cherry	+\$0
<b>JB</b>	millwork cherry	+\$0
<b>LA</b>	light ash	+\$0
<b>LBA</b>	clear on ash	+\$0
<b>LBB</b>	oak on ash	+\$0
<b>LBC</b>	walnut on ash	+\$0
<b>LBD</b>	dark brown walnut	+\$0
<b>LBE</b>	medium red walnut	+\$0
<b>LBF</b>	neutral twill	+\$0
<b>LBG</b>	sarum twill	+\$0
<b>LBH</b>	earthen twill	+\$0
<b>LBJ</b>	graphite twill	+\$0
<b>LBK</b>	pewter mesh	+\$0
<b>LBL</b>	steel mesh	+\$0
<b>LBM</b>	crisp linen	+\$0
<b>LBN</b>	classic linen	+\$0
<b>LBP</b>	casual linen	+\$0
<b>LBQ</b>	white twill	+\$0
<b>LBU</b>	medium matte walnut	+\$0
<b>LU</b>	soft white	+\$0
<b>MT</b>	medium tone	+\$0
<b>WL</b>	sandstone	+\$0

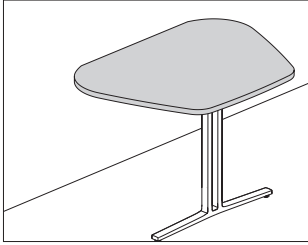

**Product Information**

**Description**

This Corian® peninsula is designed to be used with a technology cabinet or as a stand-alone surface to create a conversation zone.

**Notes**

Order surface wall attachment support (CH646.) separately.  
 Order peninsula leg (CH690.) or Ethospace® peninsula column support (E2394.DY) separately.  
 To use Flo® monitor arm attached to wall, order Flo single screen monitor arm support (Y91171.WMo) separately.  
 When specifying grommet cutout (C) option, to hide the raw wood in the hole, order Logic mini rectangle grommet (Y1412.1) separately.

**Dimensions**

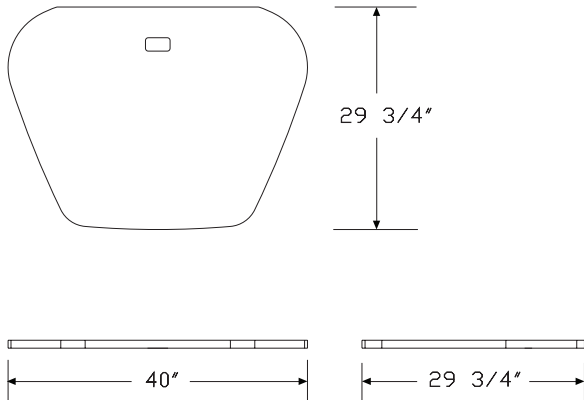

**Specification Information**

**Step 1.**

**CH680.**

**Step 2. Grommet Cutout**

- C** cutout
- N** no cutout

**Prices for Steps 1-2.**

<b>CH680. C</b>	\$1550
<b>N</b>	\$1500

**Step 3. Finish**

<b>1S</b>	savannah	+ \$250
<b>1U</b>	sahara	+ \$50
<b>4I</b>	sandstone	+ \$50
<b>58</b>	cameo white	+ \$0
<b>CQ</b>	glacier white	+ \$0
<b>CRT</b>	concrete	+ \$415
<b>FWN</b>	fawn	+ \$415
<b>OQ</b>	silt	+ \$250
<b>PGY</b>	pearl gray	+ \$415
<b>QB</b>	bisque	+ \$0
<b>SNS</b>	serene sage	+ \$415

Mora™ Surfaces

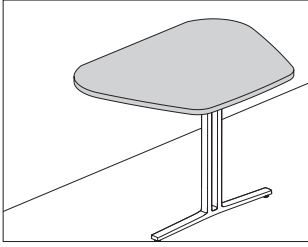

**Product Information**

**Description**  
 This HPL peninsula is designed to be used with a technology cabinet or as a stand-alone surface to create a conversation zone.

**Notes**

Order surface wall attachment support (CH646.) separately.  
 Order peninsula leg (CH690.) or Ethospace® peninsula column support (E2394.DY) separately.  
 To use Flo® monitor arm attached to wall, order Flo single screen monitor arm support (Y91171.WMoI) separately.  
 When specifying grommet cutout (C) option, to hide the raw wood in the hole, order Logic mini rectangle grommet (Y1412.1) separately.

**Dimensions**

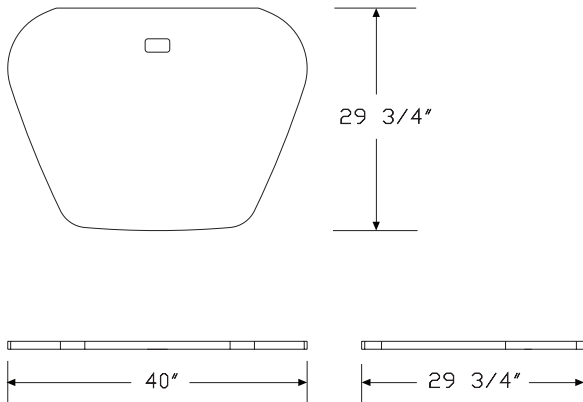

Mora™ Surfaces

**Specification Information**

Step 1.

**CH685.**  A

Step 2. Grommet Cutout

- C** cutout
- N** no cutout

Prices for Steps 1-2.

<b>CH685. C</b>	\$295
<b>N</b>	\$275

Step 3. Finish

<b>76</b>	light brown walnut	+\$0
<b>8Q</b>	folkstone grey	+\$0
<b>91</b>	white	+\$0
<b>98</b>	studio white	+\$0
<b>CL</b>	cool grey neutral	+\$0
<b>HF</b>	inner tone light	+\$0
<b>HM</b>	natural maple	+\$0
<b>HP</b>	light anigre	+\$0
<b>HT</b>	inner tone	+\$0
<b>HX</b>	aged cherry	+\$0
<b>HY</b>	walnut on cherry	+\$0
<b>LA</b>	light ash	+\$0
<b>LBA</b>	clear on ash	+\$0
<b>LBR</b>	phantom ecru	+\$0
<b>LBS</b>	phantom cocoa	+\$0
<b>LBV</b>	warm grey teak	+\$0
<b>LBU</b>	medium matte walnut	+\$0
<b>LBB</b>	oak on ash	+\$0
<b>LBC</b>	walnut on ash	+\$0
<b>LBD</b>	dark brown walnut	+\$0
<b>LBE</b>	medium red walnut	+\$0
<b>LBF</b>	neutral twill	+\$0
<b>LBG</b>	sarum twill	+\$0
<b>LBH</b>	earthen twill	+\$0
<b>LBJ</b>	graphite twill	+\$0
<b>LBK</b>	pewter mesh	+\$0
<b>LBL</b>	steel mesh	+\$0
<b>LBM</b>	crisp linen	+\$0
<b>LBN</b>	classic linen	+\$0
<b>LBP</b>	casual linen	+\$0
<b>LBQ</b>	white twill	+\$0
<b>LM</b>	mahogany	+\$0
<b>LT</b>	light tone	+\$0
<b>LU</b>	soft white	+\$0

## HPL Peninsula *continued*

<b>MT</b>	medium tone	+\$0
<b>OL</b>	white oak (nonstandard)	+\$0
<b>WL</b>	sandstone	+\$0
<b>WN</b>	warm grey neutral	+\$0
<b>ZZ</b>	open line laminate (nonstandard)	+\$20

### Step 4. Edge

<b>76</b>	light brown walnut	+\$0
<b>8Q</b>	folkstone grey	+\$0
<b>8Z</b>	neutral grey	+\$0
<b>91</b>	white	+\$0
<b>98</b>	studio white	+\$0
<b>BU</b>	black umber	+\$0
<b>CL</b>	cool grey neutral	+\$0
<b>HF</b>	inner tone light	+\$0
<b>HM</b>	natural maple	+\$0
<b>HP</b>	light anigre	+\$0
<b>HT</b>	inner tone	+\$0
<b>HX</b>	aged cherry	+\$0
<b>HY</b>	walnut on cherry	+\$0
<b>JB</b>	millwork cherry	+\$0
<b>LA</b>	light ash	+\$0
<b>LBA</b>	clear on ash	+\$0
<b>LBR</b>	phantom ecru	+\$0
<b>LBS</b>	phantom cocoa	+\$0
<b>LBV</b>	warm grey teak	+\$0
<b>LBU</b>	medium matte walnut	+\$0
<b>LBB</b>	oak on ash	+\$0
<b>LBC</b>	walnut on ash	+\$0
<b>LBD</b>	dark brown walnut	+\$0
<b>LBE</b>	medium red walnut	+\$0
<b>LBF</b>	neutral twill	+\$0
<b>LBG</b>	sarum twill	+\$0
<b>LBH</b>	earthen twill	+\$0
<b>LBJ</b>	graphite twill	+\$0
<b>LBK</b>	pewter mesh	+\$0
<b>LBL</b>	steel mesh	+\$0
<b>LBM</b>	crisp linen	+\$0
<b>LBN</b>	classic linen	+\$0
<b>LBP</b>	casual linen	+\$0
<b>LBQ</b>	white twill	+\$0
<b>LU</b>	soft white	+\$0
<b>MT</b>	medium tone	+\$0
<b>WL</b>	sandstone	+\$0
<b>WN</b>	warm grey neutral	+\$0

# Peninsula Leg

CH690.

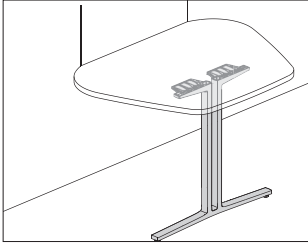

### Product Information

**Description**  
This peninsula leg supports Corian® and HPL peninsulas. Attachment hardware included.

### Notes

Order peninsulas separately:  
 • Corian peninsula (CH680.)  
 • HPL peninsula (CH685.)

### Dimensions

Mora™ Surfaces

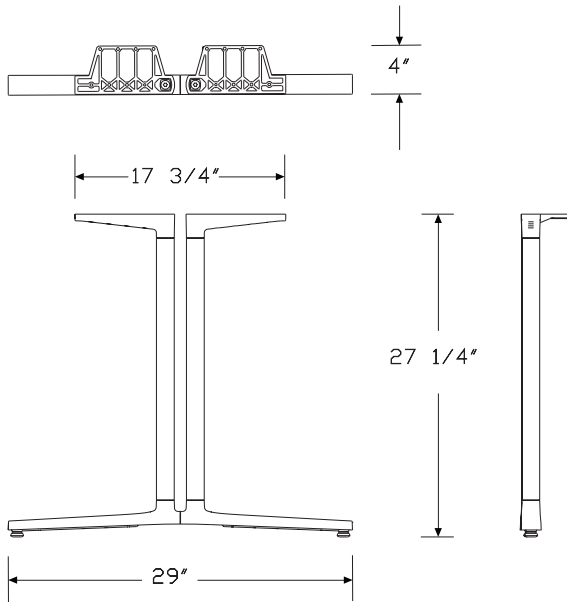

### Specification Information

#### Step 1.

**CH690.**

#### Step 2. Style

**E** everywhere leg

#### Prices for Steps 1-2.

**CH690. E** \$220

#### Step 3. Finish

<b>BU</b>	black umber	+ \$0
<b>8Q</b>	folkstone grey	+ \$0
<b>91</b>	white	+ \$0
<b>CL</b>	cool grey neutral	+ \$0
<b>G2</b>	graphite satin	+ \$0
<b>HF</b>	inner tone light	+ \$0
<b>LU</b>	soft white	+ \$0
<b>MT</b>	medium tone	+ \$0
<b>SG</b>	slate grey	+ \$0
<b>WL</b>	sandstone	+ \$0
<b>WN</b>	warm grey neutral	+ \$0
<b>CN</b>	metallic champagne	+ \$0
<b>EH</b>	metallic bronze	+ \$0
<b>MS</b>	metallic silver	+ \$0
<b>CD</b>	polished aluminum	+ \$70



# Peninsula Column Support

E2394.

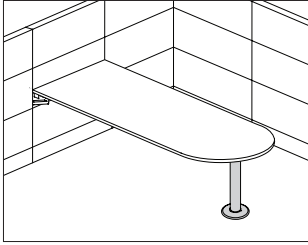

### Product Information

#### Description

This column attaches to the far end of a peninsula or D-shaped surface. The column adjusts the work surface height from 27<sup>1</sup>/<sub>2</sub>" to 31<sup>1</sup>/<sub>2</sub>". Attachment hardware is included.

#### Dimensions

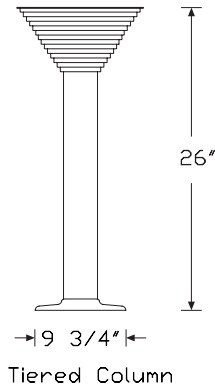
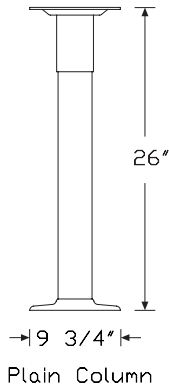
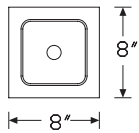

### Specification Information

#### Step 1.

**E2394.**

#### Step 2. Column Option

- DY** plain column
- DZ** tiered column

#### Prices for Steps 1-2.

<b>E2394. DY</b>	\$274
<b>DZ</b>	\$274

#### Step 3. Surface Finish

<b>8Q</b>	folkstone grey	+\$0
<b>91</b>	white	+\$0
<b>BU</b>	black umber	+\$0
<b>HF</b>	inner tone light	+\$0
<b>LU</b>	soft white	+\$0
<b>MT</b>	medium tone	+\$0
<b>SG</b>	slate grey	+\$0
<b>WL</b>	sandstone	+\$0
<b>CN</b>	metallic champagne	+\$0
<b>EH</b>	metallic bronze	+\$0
<b>MS</b>	metallic silver	+\$0

Mora™ Surfaces

# Wall-Mounted Technology Cabinet

CH700.

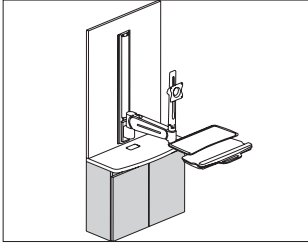

## Product Information

### Description

This wall-mounted technology cabinet is designed to conceal a CPU. A peninsula or small technology cabinet surface complete the solution.

### Notes

Bottom panel inside cabinet has 1" gap along back edge for venting.

Cabinet comes standard with cutout in top for wire management.

Order the following products separately:

- Corian® peninsula (CH680.)
- HPL peninsula (CH685.)
- Small technology cabinet surface (CH710.)
- Backdrop panel (CH670.)
- Hanging cleat (CH100.)
- Thrive® wall-mounted technology supports

### Dimensions

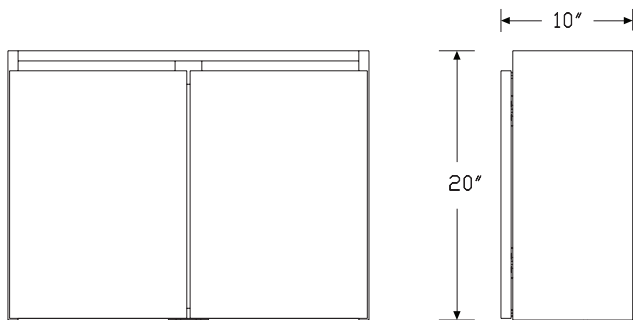
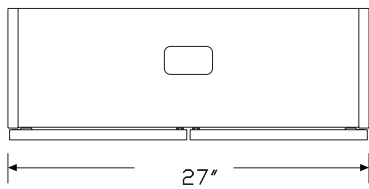

## Specification Information

### Step 1.

**CH700.**

### Step 2. Width

**27** 27" wide +\$790

### Step 3. Depth

**09** 9" deep +\$0

### Step 4. Material

**H** high-pressure laminate +\$220

**L** low-pressure laminate +\$0

### Step 5. Grain Direction

**HRG** horizontal grain +\$0

**VTG** vertical grain +\$0

# Wall-Mounted Technology Cabinet *continued*

## Step 6. Finish

### *For low-pressure laminate (L)*

<b>76</b>	light brown walnut	+\$0
<b>8Q</b>	folkstone grey	+\$0
<b>91</b>	white	+\$0
<b>98</b>	studio white	+\$0
<b>CL</b>	cool grey neutral	+\$0
<b>HM</b>	natural maple	+\$0
<b>HP</b>	light anigre	+\$0
<b>HX</b>	aged cherry	+\$0
<b>HY</b>	walnut on cherry	+\$0
<b>LA</b>	light ash	+\$0
<b>LBA</b>	clear on ash	+\$0
<b>LBB</b>	oak on ash	+\$0
<b>LBC</b>	walnut on ash	+\$0
<b>LBD</b>	dark brown walnut	+\$0
<b>LBE</b>	medium red walnut	+\$0
<b>LBF</b>	neutral twill	+\$0
<b>LBG</b>	sarum twill	+\$0
<b>LBH</b>	earthen twill	+\$0
<b>LBJ</b>	graphite twill	+\$0
<b>LBK</b>	pewter mesh	+\$0
<b>LBL</b>	steel mesh	+\$0
<b>LBM</b>	crisp linen	+\$0
<b>LBN</b>	classic linen	+\$0
<b>LBP</b>	casual linen	+\$0
<b>LBQ</b>	white twill	+\$0
<b>LBR</b>	phantom ecru	+\$0
<b>LBS</b>	phantom cocoa	+\$0
<b>LBU</b>	medium matte walnut	+\$0
<b>LBV</b>	warm grey teak	+\$0
<b>LU</b>	soft white	+\$0
<b>WL</b>	sandstone	+\$0
<b>WN</b>	warm grey neutral	+\$0

### *For high-pressure laminate (H)*

<b>76</b>	light brown walnut	+\$0
<b>8Q</b>	folkstone grey	+\$0
<b>91</b>	white	+\$0
<b>98</b>	studio white	+\$0
<b>CL</b>	cool grey neutral	+\$0
<b>HF</b>	inner tone light	+\$0
<b>HM</b>	natural maple	+\$0
<b>HP</b>	light anigre	+\$0
<b>HT</b>	inner tone	+\$0
<b>HX</b>	aged cherry	+\$0

<b>HY</b>	walnut on cherry	+\$0
<b>LA</b>	light ash	+\$0
<b>LBA</b>	clear on ash	+\$0
<b>LBB</b>	oak on ash	+\$0
<b>LBC</b>	walnut on ash	+\$0
<b>LBD</b>	dark brown walnut	+\$0
<b>LBE</b>	medium red walnut	+\$0
<b>LBF</b>	neutral twill	+\$0
<b>LBG</b>	sarum twill	+\$0
<b>LBH</b>	earthen twill	+\$0
<b>LBJ</b>	graphite twill	+\$0
<b>LBK</b>	pewter mesh	+\$0
<b>LBL</b>	steel mesh	+\$0
<b>LBM</b>	crisp linen	+\$0
<b>LBN</b>	classic linen	+\$0
<b>LBP</b>	casual linen	+\$0
<b>LBQ</b>	white twill	+\$0
<b>LBR</b>	phantom ecru	+\$0
<b>LBS</b>	phantom cocoa	+\$0
<b>LBU</b>	medium matte walnut	+\$0
<b>LBV</b>	warm grey teak	+\$0
<b>LM</b>	mahogany	+\$0
<b>LT</b>	light tone	+\$0
<b>LU</b>	soft white	+\$0
<b>MT</b>	medium tone	+\$0
<b>WL</b>	sandstone	+\$0
<b>WN</b>	warm grey neutral	+\$0

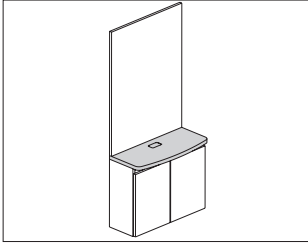

**Product Information**

**Description**  
 This HPL surface finishes off a technology cabinet and provides a small storage surface. Attachment hardware included.

**Notes**  
 Order technology cabinet (CH700.) separately.  
 To hide the raw wood in the cutout, order Logic mini rectangle grommet (Y1412.1) separately.

**Dimensions**

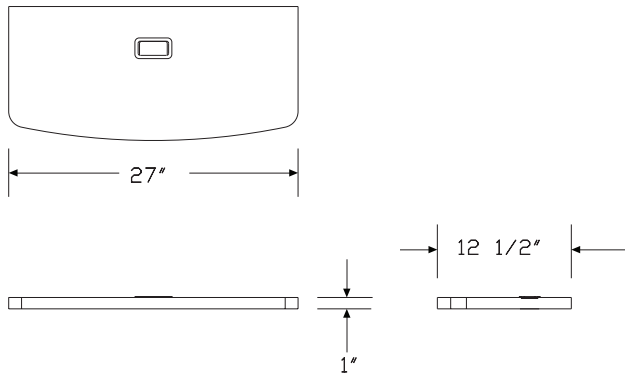

Mora™ Technology Support Solutions

**Specification Information**

**Step 1.**  
**CH710.** \$180

**Step 2. Finish**

<b>LBR</b>	phantom ecru	+\$0
<b>LBS</b>	phantom cocoa	+\$0
<b>LBV</b>	warm grey teak	+\$0
<b>76</b>	light brown walnut	+\$0
<b>8Q</b>	folkstone grey	+\$0
<b>91</b>	white	+\$0
<b>98</b>	studio white	+\$0
<b>CL</b>	cool grey neutral	+\$0
<b>HF</b>	inner tone light	+\$0
<b>HM</b>	natural maple	+\$0
<b>HP</b>	light anigre	+\$0
<b>HT</b>	inner tone	+\$0
<b>HX</b>	aged cherry	+\$0
<b>HY</b>	walnut on cherry	+\$0
<b>LA</b>	light ash	+\$0
<b>LBA</b>	clear on ash	+\$0
<b>LBB</b>	oak on ash	+\$0
<b>LBC</b>	walnut on ash	+\$0
<b>LBD</b>	dark brown walnut	+\$0
<b>LBE</b>	medium red walnut	+\$0
<b>LBF</b>	neutral twill	+\$0
<b>LBG</b>	sarum twill	+\$0
<b>LBH</b>	earthen twill	+\$0
<b>LBJ</b>	graphite twill	+\$0
<b>LBK</b>	pewter mesh	+\$0
<b>LBL</b>	steel mesh	+\$0
<b>LBM</b>	crisp linen	+\$0
<b>LBN</b>	classic linen	+\$0
<b>LBP</b>	casual linen	+\$0
<b>LBQ</b>	white twill	+\$0
<b>LBU</b>	medium matte walnut	+\$0
<b>LM</b>	mahogany	+\$0
<b>LT</b>	light tone	+\$0
<b>LU</b>	soft white	+\$0
<b>MT</b>	medium tone	+\$0
<b>OL</b>	white oak (nonstandard)	+\$0
<b>WL</b>	sandstone	+\$0
<b>WN</b>	warm grey neutral	+\$0
<b>ZZ</b>	open line laminate (nonstandard)	+\$20

**Step 3. Edge Finish**

<b>LBR</b>	phantom ecru	+\$0
------------	--------------	------

Small Tech Cabinet Surface *continued*

<b>LBS</b>	phantom cocoa	+\$0
<b>LBV</b>	warm grey teak	+\$0
<b>76</b>	light brown walnut	+\$0
<b>8Q</b>	folkstone grey	+\$0
<b>8Z</b>	neutral grey	+\$0
<b>91</b>	white	+\$0
<b>98</b>	studio white	+\$0
<b>BU</b>	black umber	+\$0
<b>CL</b>	cool grey neutral	+\$0
<b>HF</b>	inner tone light	+\$0
<b>HM</b>	natural maple	+\$0
<b>HP</b>	light anigre	+\$0
<b>HT</b>	inner tone	+\$0
<b>HX</b>	aged cherry	+\$0
<b>HY</b>	walnut on cherry	+\$0
<b>JB</b>	millwork cherry	+\$0
<b>LA</b>	light ash	+\$0
<b>LBA</b>	clear on ash	+\$0
<b>LBB</b>	oak on ash	+\$0
<b>LBC</b>	walnut on ash	+\$0
<b>LBD</b>	dark brown walnut	+\$0
<b>LBE</b>	medium red walnut	+\$0
<b>LBF</b>	neutral twill	+\$0
<b>LBG</b>	sarum twill	+\$0
<b>LBH</b>	earthen twill	+\$0
<b>LBJ</b>	graphite twill	+\$0
<b>LBK</b>	pewter mesh	+\$0
<b>LBL</b>	steel mesh	+\$0
<b>LBM</b>	crisp linen	+\$0
<b>LBN</b>	classic linen	+\$0
<b>LBP</b>	casual linen	+\$0
<b>LBQ</b>	white twill	+\$0
<b>LBU</b>	medium matte walnut	+\$0
<b>LU</b>	soft white	+\$0
<b>MT</b>	medium tone	+\$0
<b>WL</b>	sandstone	+\$0
<b>WN</b>	warm grey neutral	+\$0

# In-line Technology Cabinet

CH720.

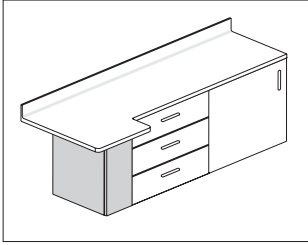

## Product Information

**Description**  
 This wall-mounted CPU cabinet accommodates a CPU and attaches next to other wall cabinets, under the work end of surfaces with a work end.

**Notes**  
 Order the following products separately:  
 • Hanging cleat (CH100.)  
 • Work surface with work end (CH610., CH615., CH616., CH630.)  
 • Ganging hardware pack (CH110.)  
 Hinge is on same side as run of cabinets.

## Dimensions

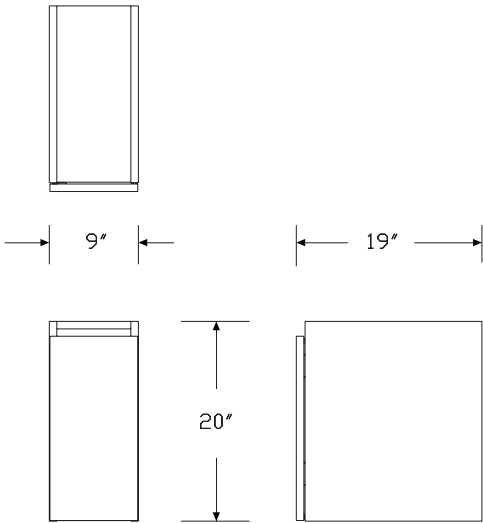

## Specification Information

Step 1.		
<b>CH720.</b>		
Step 2. Width		
<b>09</b>	9" wide	+\$580
Step 3. Depth		
<b>19</b>	19" deep	+\$0
Step 4. Material		
<b>H</b>	high-pressure laminate	+\$150
<b>L</b>	low-pressure laminate	+\$0
Step 5. Location in Run		
<b>L</b>	left finished end	+\$0
<b>M</b>	middle of run	+\$0
<b>R</b>	right finished end	+\$0
Step 6. Grain Direction		
<b>HRG</b>	horizontal grain	+\$0
<b>VTG</b>	vertical grain	+\$0

# In-line Technology Cabinet *continued*

## Step 7. Case Finish

### *For low-pressure laminate (L)*

<b>76</b>	light brown walnut	+\$0
<b>8Q</b>	folkstone grey	+\$0
<b>91</b>	white	+\$0
<b>98</b>	studio white	+\$0
<b>CL</b>	cool grey neutral	+\$0
<b>HM</b>	natural maple	+\$0
<b>HP</b>	light anigre	+\$0
<b>HX</b>	aged cherry	+\$0
<b>HY</b>	walnut on cherry	+\$0
<b>LA</b>	light ash	+\$0
<b>LBA</b>	clear on ash	+\$0
<b>LBB</b>	oak on ash	+\$0
<b>LBC</b>	walnut on ash	+\$0
<b>LBD</b>	dark brown walnut	+\$0
<b>LBE</b>	medium red walnut	+\$0
<b>LBF</b>	neutral twill	+\$0
<b>LBG</b>	sarum twill	+\$0
<b>LBH</b>	earthen twill	+\$0
<b>LBJ</b>	graphite twill	+\$0
<b>LBK</b>	pewter mesh	+\$0
<b>LBL</b>	steel mesh	+\$0
<b>LBM</b>	crisp linen	+\$0
<b>LBN</b>	classic linen	+\$0
<b>LBP</b>	casual linen	+\$0
<b>LBQ</b>	white twill	+\$0
<b>LBR</b>	phantom ecru	+\$0
<b>LBS</b>	phantom cocoa	+\$0
<b>LBU</b>	medium matte walnut	+\$0
<b>LBV</b>	warm grey teak	+\$0
<b>LU</b>	soft white	+\$0
<b>WL</b>	sandstone	+\$0
<b>WN</b>	warm grey neutral	+\$0

### *For high-pressure laminate (H)*

<b>76</b>	light brown walnut	+\$0
<b>8Q</b>	folkstone grey	+\$0
<b>91</b>	white	+\$0
<b>98</b>	studio white	+\$0
<b>CL</b>	cool grey neutral	+\$0
<b>HF</b>	inner tone light	+\$0
<b>HM</b>	natural maple	+\$0
<b>HP</b>	light anigre	+\$0
<b>HT</b>	inner tone	+\$0
<b>HX</b>	aged cherry	+\$0

<b>HY</b>	walnut on cherry	+\$0
<b>LA</b>	light ash	+\$0
<b>LBA</b>	clear on ash	+\$0
<b>LBB</b>	oak on ash	+\$0
<b>LBC</b>	walnut on ash	+\$0
<b>LBD</b>	dark brown walnut	+\$0
<b>LBE</b>	medium red walnut	+\$0
<b>LBF</b>	neutral twill	+\$0
<b>LBG</b>	sarum twill	+\$0
<b>LBH</b>	earthen twill	+\$0
<b>LBJ</b>	graphite twill	+\$0
<b>LBK</b>	pewter mesh	+\$0
<b>LBL</b>	steel mesh	+\$0
<b>LBM</b>	crisp linen	+\$0
<b>LBN</b>	classic linen	+\$0
<b>LBP</b>	casual linen	+\$0
<b>LBQ</b>	white twill	+\$0
<b>LBR</b>	phantom ecru	+\$0
<b>LBS</b>	phantom cocoa	+\$0
<b>LBU</b>	medium matte walnut	+\$0
<b>LBV</b>	warm grey teak	+\$0
<b>LM</b>	mahogany	+\$0
<b>LT</b>	light tone	+\$0
<b>LU</b>	soft white	+\$0
<b>MT</b>	medium tone	+\$0
<b>OL</b>	white oak (nonstandard)	+\$0
<b>WL</b>	sandstone	+\$0
<b>WN</b>	warm grey neutral	+\$0

# Coat Hook

CH800.

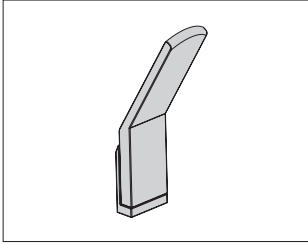

### Product Information

**Description**  
This coat hook attaches to the sides of towers or to a wall. Attachment hardware included.

### Dimensions

### Specification Information

<b>Step 1.</b>	
<b>CH800.</b>	\$20
<b>Step 2. Finish</b>	
<b>NH</b> brushed nickel	+\$0

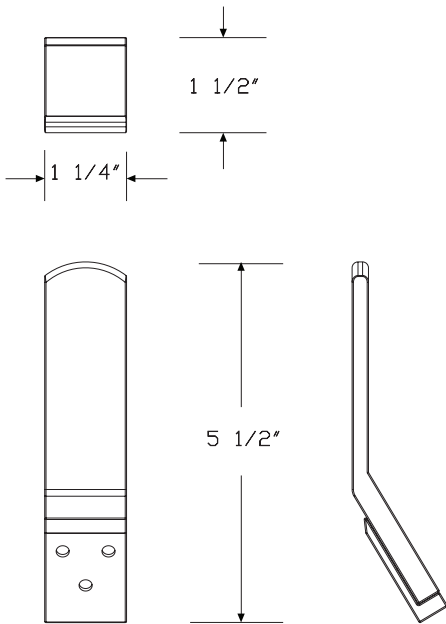

Mora™ Accessories



# Accessory Rail

TW700.

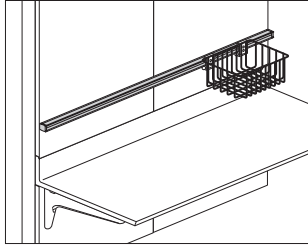

### Product Information

#### Description

This aluminum rail attaches to the front of a tile to hold rail-mounted components. It has a satin oxide laminate insert and grey end caps. Attachment hardware included.

#### Notes

Rail can match tile width, or span multiple tiles. For easy removal of tiles, accessory rail width should be equal to or less than the width of the tile it's attached to.

#### Dimensions

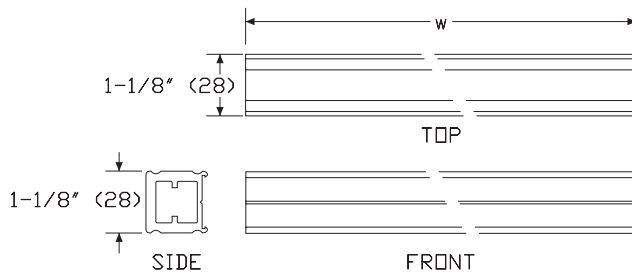

### Specification Information

#### Step 1.

**TW700.**

#### Step 2. Width

<b>18</b>	18" wide
<b>24</b>	24" wide
<b>30</b>	30" wide
<b>36</b>	36" wide
<b>42</b>	42" wide
<b>48</b>	48" wide

#### Prices for Steps 1-2.

<b>TW700. 18</b>	\$72
<b>24</b>	\$95
<b>30</b>	\$119
<b>36</b>	\$142
<b>42</b>	\$167
<b>48</b>	\$188

Mora™ Accessories

# Universal Rail Clamp

TW705.

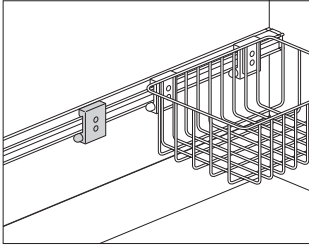

### Product Information

**Description**  
This universal aluminum clamp attaches to an accessory rail and has holes for attaching customer supplied components. It has a push button mechanism that locks the clamp in place and allows for easy attachment and removal.

**Notes**  
Order accessory rail (TW700.) separately.

### Dimensions

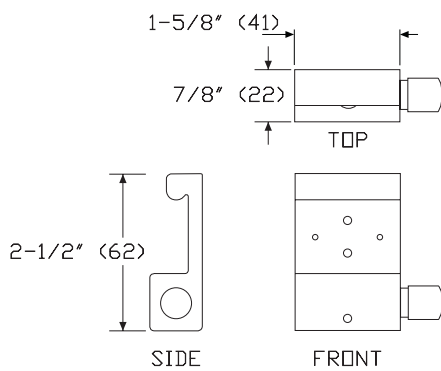

### Specification Information

Step 1.  
**TW705.** \$121

# Soap and Sanitizer Mounting Bracket

TW706.

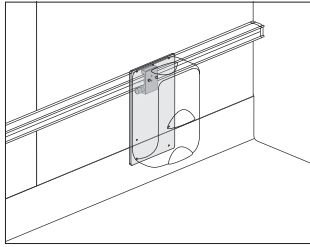

## Product Information

### Description

This aluminum mounting bracket is designed for use with customer supplied components such as soap and sanitizer dispensers or sharps containers. It includes 1 universal rail clamp (TW705.) for attachment. The clamp has a push-button locking mechanism for easy attachment and removal.

### Notes

Order accessory rail (TW700.) separately. Screws must be customer supplied.

### Dimensions

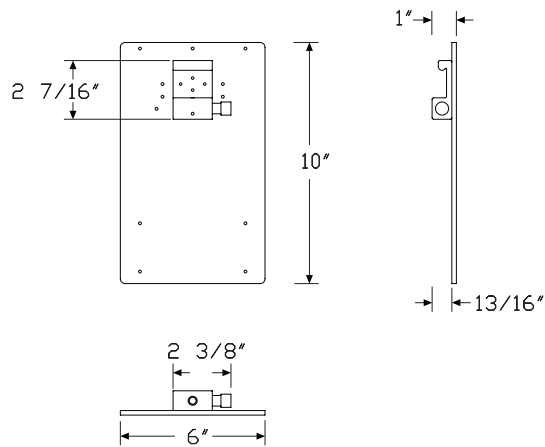

## Specification Information

### Step 1.

**TW706.**

\$396

# Paper Towel Dispenser Mounting Bracket TW707.

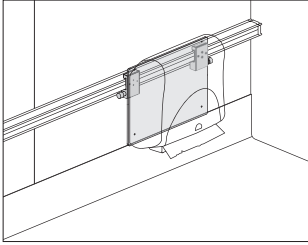

## Product Information

**Description**  
 This aluminum mounting bracket is designed for use with customer supplied paper towel dispensers. It includes 2 universal rail clamps (TW705.) for attachment. The clamps have a push-button locking mechanism for easy attachment and removal.

**Notes**  
 Order accessory rail (TW700.) separately. Screws and dispensers must be customer supplied.  
 Wide paper towel dispenser dimensions are approximately 10" wide x 5" deep x 8" high. Tall dispenser dimensions are approximately 13" wide x 9" deep x 13" high.  
 See Compass™ planning guide for additional specification information.

## Dimensions

Mora™ Accessories

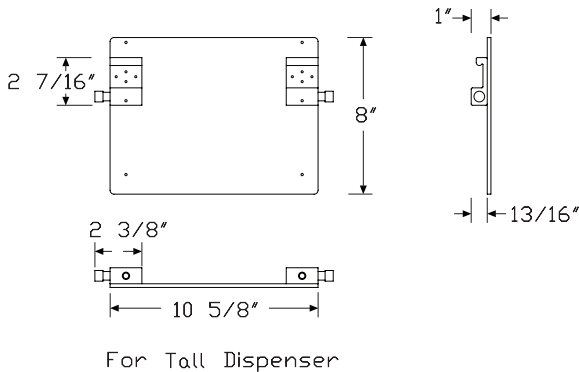
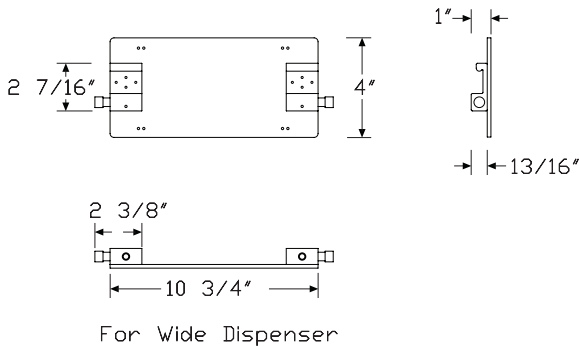

## Specification Information

**Step 1.**  
**TW707.**

**Step 2. Size**  
**A** used with wide paper towel dispensers  
**B** used with tall paper towel dispensers

Prices for Steps 1-2.

<b>TW707.A</b>	\$447
<b>B</b>	\$447

# Utility Basket

TW720.

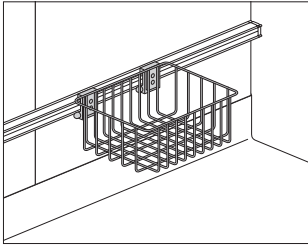

### Product Information

#### Description

This powder-coated wire basket attaches to an accessory rail to hold small items. It includes 2 rail clamps for attachment. The clamps have a push button mechanism that locks the clamp in place and allows for easy attachment and removal. Finish is off-white.

#### Notes

Order accessory rail (TW700.) separately.

#### Dimensions

### Specification Information

#### Step 1.

**TW720.**

#### Step 2. Size

- 01** 4" high x 8" deep x 10" wide
- 02** 7" high x 8" deep x 10" wide

#### Prices for Steps 1-2.

<b>TW720.01</b>	\$409
<b>02</b>	\$424

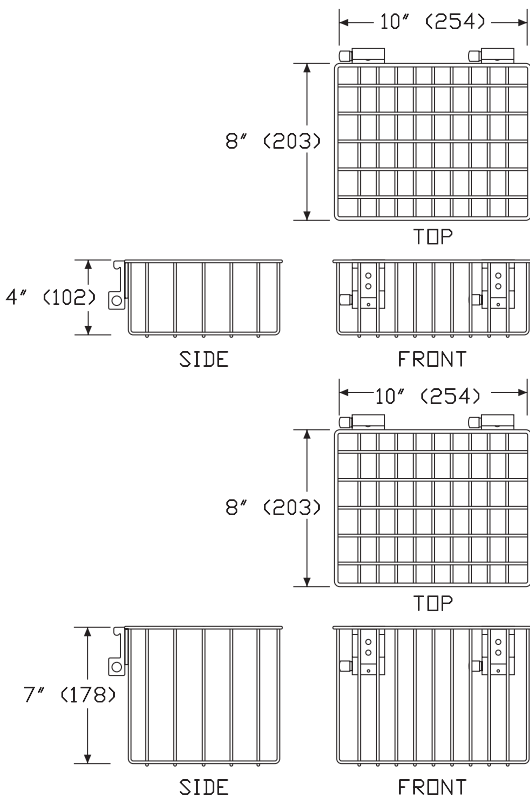

# Sharps Container Holder

TW722.

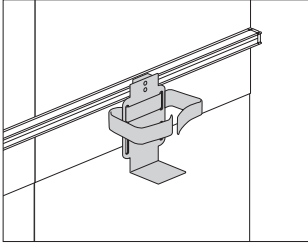

### Product Information

**Description**  
This painted holder attaches to an accessory rail and has a strap for holding a variety of customer-supplied sharps containers. It includes a rail clamp for attachment. The clamp has a push button mechanism that locks the clamp in place and allows for easy attachment and removal. Finish is off-white.

### Notes

Order accessory rail (TW700.) separately.

### Dimensions

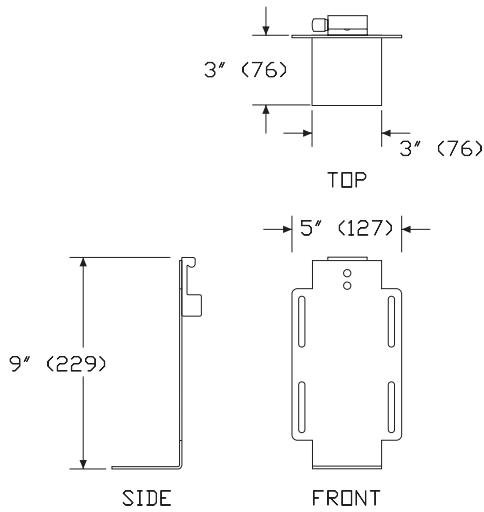

### Specification Information

Step 1.  
**TW722.** \$301

# Vacuum Bottle Slide

TW723.

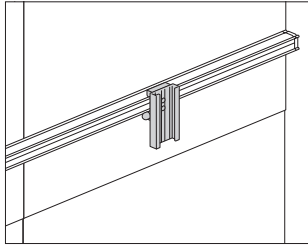

### Product Information

#### Description

This aluminum slide attaches to an accessory rail and accepts a customer-supplied vacuum bottle with mounting ring. It includes a rail clamp for attachment. The clamp has a push button mechanism that locks the clamp in place and allows for easy attachment and removal.

#### Notes

Order accessory rail (TW700.) separately.

#### Dimensions

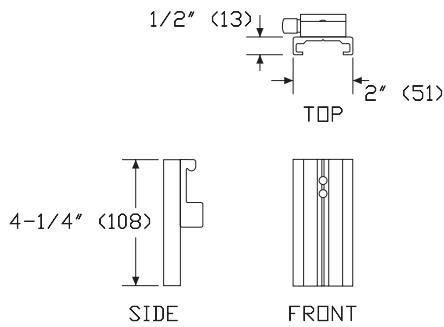

### Specification Information

#### Step 1.

**TW723.**

\$147

# Glove Box Holder

TW724.

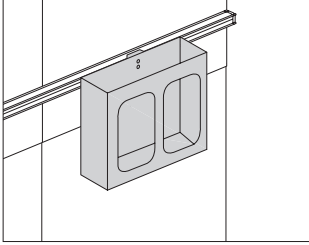

### Product Information

#### Description

This holder attaches to an accessory rail and holds 2 10" x 5" x 3" boxes of gloves. It includes a rail clamp for attachment. The clamp has a push button mechanism that locks the clamp in place and allows for easy attachment and removal. Finish is off-white

#### Notes

Order accessory rail (TW700.) separately.

#### Dimensions

### Specification Information

#### Step 1.

**TW724.**

\$507

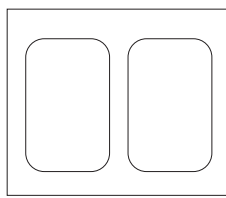
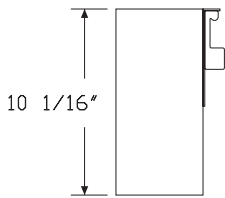
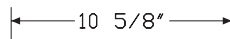
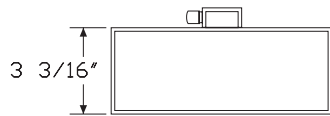

Mora™ Accessories



### 3 Clip Organizer

TW725.

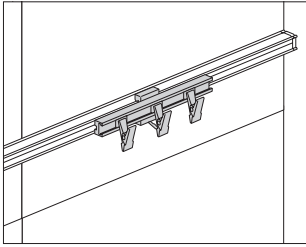

#### Product Information

##### Description

This aluminum organizer attaches to an accessory rail and has 3 stainless steel clips for holding IV bags, catheters, and other items. It includes a rail clamp for attachment.

##### Notes

Order accessory rail (TW700.) separately.

##### Dimensions

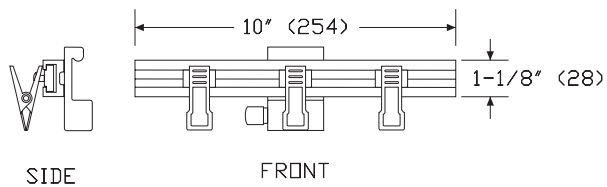

#### Specification Information

##### Step 1.

**TW725.**

\$320

# Instrument Mounting Bracket

TW726.

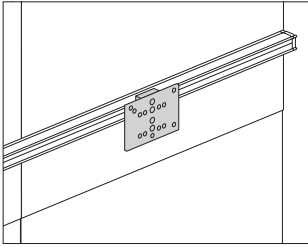

### Product Information

**Description**  
This aluminum bracket attaches to an accessory rail to hold a customer-supplied sphygmomanometer, ophthalmoscope with holder, or thermometer with holder. It is designed for products that adhere to the Fairfield standards. The bracket includes a rail clamp for attachment. The clamp has a push button mechanism that locks the clamp in place and allows for easy attachment and removal.

### Notes

Order accessory rail (TW700.) separately.

### Dimensions

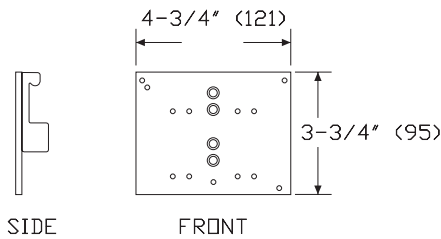

### Specification Information

Step 1.  
**TW726.** \$314

# Sphygmomanometer Basket

TW727.

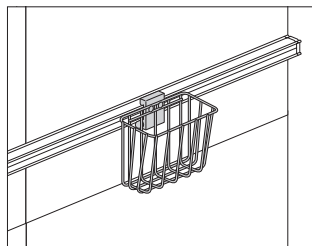

### Product Information

#### Description

This stainless steel wire basket attaches to an accessory rail to hold a customer-supplied blood pressure arm cuff or other small items. It includes a rail clamp for attachment. The clamp has a push button mechanism that locks the clamp in place and allows for easy attachment and removal.

#### Notes

Order accessory rail (TW700.) separately.

#### Dimensions

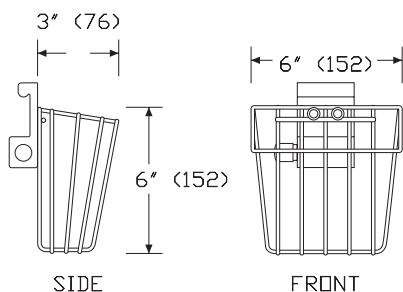

### Specification Information

#### Step 1.

**TW727.**

\$264

# Mounting Clamp

TW740.

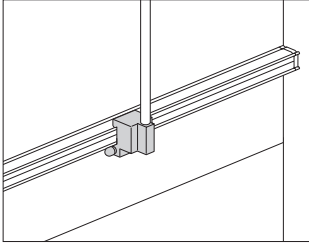

### Product Information

#### Description

This aluminum clamp attaches to an accessory rail to hold components with a post-mount attachment method. It has a push button mechanism that locks the clamp in place and allows for easy attachment and removal.

#### Notes

Order the following products separately:

- Accessory rail (TW700.)
- Chart holder (TW746.)
- IV pole (TW743.)
- Utility Hook (TW747.)

#### Dimensions

### Specification Information

#### Step 1.

**TW740.**

\$156

Mora™ Accessories

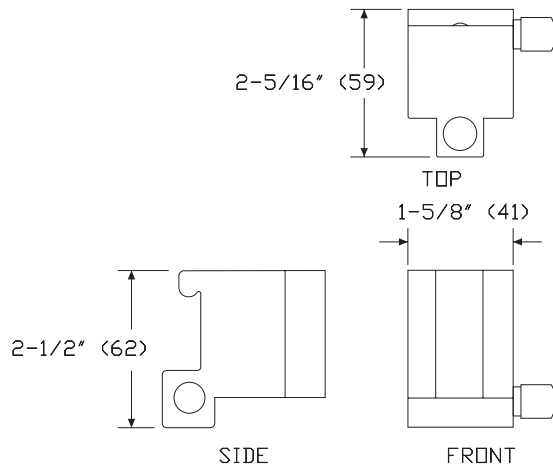

IV Pole

TW743.

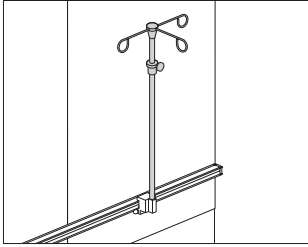

**Product Information**

**Description**

This adjustable stainless steel pole holds up to 3 IV bags and has a post for attaching to a mounting clamp.

**Notes**

Order accessory rail (TW700.) and mounting clamp (TW740.) separately.

**Dimensions**

**Specification Information**

Step 1.

**TW743.24**

\$516

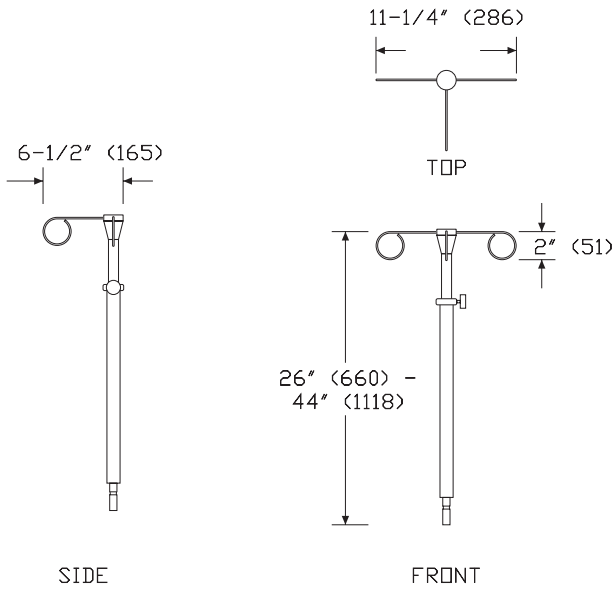

Mora™ Accessories

# Chart Holder

TW746.

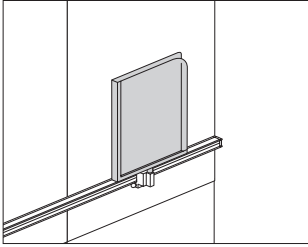

### Product Information

**Description**  
This powder-coated holder has a clear acrylic front and holds a chart or other paper items. It has a post for attaching to a mounting clamp. Finish is off-white.

**Notes**  
Order accessory rail (TW700.) and mounting clamp (TW740.) separately.

### Dimensions

### Specification Information

Step 1.  
**TW746.** \$363

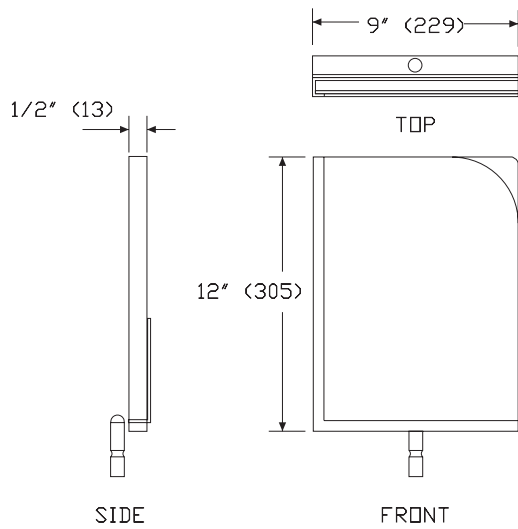

Mora™ Accessories

# Utility Hook

TW747.

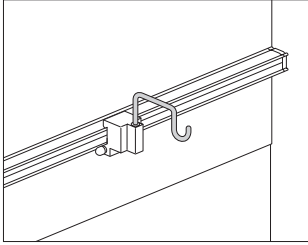

### Product Information

#### Description

This stainless steel hook holds tubing, charts, catheters, or other equipment. It has a post for attaching to a mounting clamp.

#### Notes

Order accessory rail (TW700.) and mounting clamp (TW740.) separately.

#### Dimensions

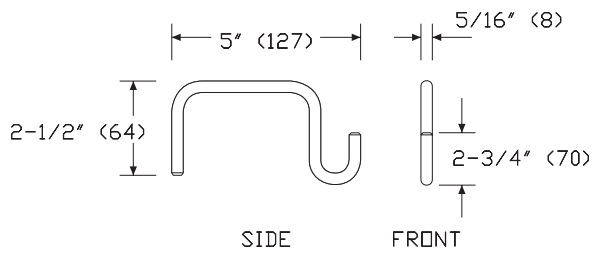

### Specification Information

Step 1.

**TW747.**

\$95

# Mbrace Wall-Mounted Technology Y94015

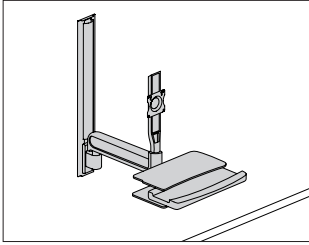

## Product Information

### Description

This wall-mounted technology combo arm allows the keyboard and monitor to effortlessly move together as a single unit, and mounts to either a 34" wall track. This solution can support up to 20 pounds and be adjusted with one hand through 22" of vertical adjustment and 9½" of independent, knob-free monitor adjustment. The monitor float tower and keyboard tray can rotate independently of each other. This solution can also store in as little as 10" of space and can be installed on Compass™ wall tiles and directly to drywall. Rotation limiter and cable management included.

### Notes

All painted surfaces are finished with anti-microbial powder coat paint to support infectious control policies.

OSHDP and Engineer certified.

Supports 75mm and 100mm VESA patterns.

Fasteners provided for virtually all applications except masonry surfaces.

Additional accessories sold separately:

- Track Mount Small Cradle CPU Support (Y94100.)
- Track Mount CPU Enclosure (Y94102.)

## Dimensions

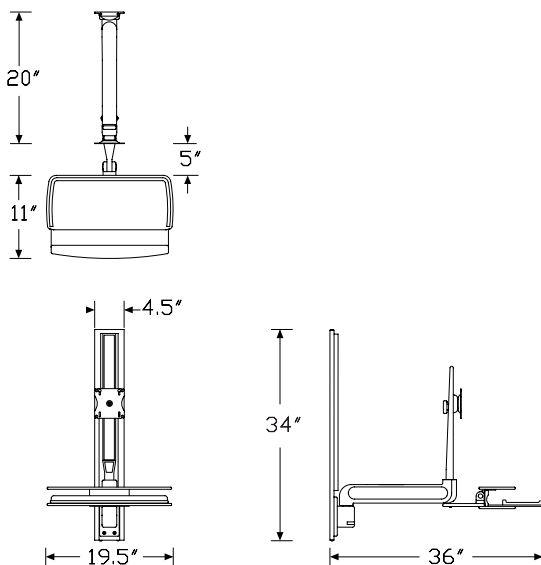

## Specification Information

### Step 1.

**Y94015.**  A

### Step 2. Track Length

**34** 34" long  A

### Prices for Steps 1-2.

**Y94015. 34** \$1900

### Step 3. Arm Finish

**0J** white  A +\$0



# Mbrace Extension Arm

Y94105

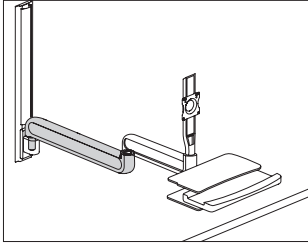

### Product Information

#### Description

This extension arm adds 20" of horizontal movement. It can be retrofitted in the field.

#### Notes

All painted surfaces are finished with anti-microbial powder coat paint to support infectious control policies.

Engineer certified.

Supports 75mm and 100mm VESA patterns.

Extension arm can be used with the following products:

- Mbrace wall-mounted technology (Y94015.)

### Dimensions

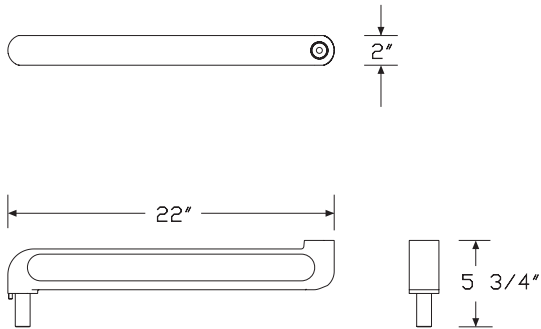

### Specification Information

Step 1.

Y94105. A

\$365



# Index by Product Name

<b>Mora™ System</b>	
1" Shelf for Shelf Towers	page(s) 66
3 Clip Organizer	117
Accessory Rail	109
ADA Sink Enclosure	25
Awning Overhead Storage	31
Backdrop Panel	93
Cantilever	91
Chart Holder	122
Coat Hook	108
Corian Peninsula	97
Corian Work Surface	69
Corian Work Surface with ADA Sink	75
Corian Work Surface with Oval Sink	71
Corian Work Surface with Rectangular Sink	73
Corian Work Surface with Work End	77
Corian Work Surface with Work End and Oval Sink	78
Corian Work Surface with Work End and Rectangular Sink	79
End Panel	89
Floating Shelf	95
Ganging Hardware Pack	7
Glove Box Holder	116
Hanging Cleat	5
Hanging Cleat Hardware Pack	6
HPL Backsplash	87
HPL Peninsula	98
HPL Work Surface	82
HPL Work Surface with Work End	84
In-line Technology Cabinet	106
Instrument Mounting Bracket	118
IV Pole	121
Mbrace Extension Arm	125
Mbrace Wall-Mounted Technology	124
Mounting Clamp	120
Open Shelving Overheads	33
Overhead Storage	27
Paper Towel Dispenser Mounting Bracket	112
Peninsula Column Support	101
Peninsula Leg	100
Plinth Base - Finished	22
Plinth Base - Unfinished	24
Sharps Container Holder	114
Sidesplash	81
Sloped Top Awning Overhead Storage	44
Sloped Top Open Shelving Overheads	46
Sloped Top Overhead Storage	40
Sloped Top Panel	38

Sloped Top To-the-Floor Door Towers	60
Sloped Top Wall-Mounted Door Towers	57
Small Tech Cabinet Surface	104
Soap and Sanitizer Mounting Bracket	111
Soffit	36
Sphygmomanometer Basket	119
Straight Filler	67
Surface Wall Attachment Support	86
To-The-Floor Door Cases	18
To-The-Floor Door Towers	54
To-The-Floor Drawer Cases	15
Tower Sloped Top Panel	49
Universal Rail Clamp	110
Utility Basket	113
Utility Hook	123
Vacuum Bottle Slide	115
Wall Mounted Door Case	11
Wall-Mounted Door Towers	51
Wall Mounted Drawer Cases	8
Wall-Mounted Shelf Towers	63
Wall-Mounted Technology Cabinet	102

Index: Product Name



# Index by Product Number

CH100. Hanging Cleat	page(s) 5	CH720. In-line Technology Cabinet	106
CH105. Hanging Cleat Hardware Pack	6	CH800. Coat Hook	108
CH110. Ganging Hardware Pack	7	E2394. Peninsula Column Support	101
CH200. Wall Mounted Drawer Cases	8	TW700. Accessory Rail	109
CH210. Wall Mounted Door Case	11	TW705. Universal Rail Clamp	110
CH220. To-The-Floor Drawer Cases	15	TW706. Soap and Sanitizer Mounting Bracket	111
CH230. To-The-Floor Door Cases	18	TW707. Paper Towel Dispenser Mounting Bracket	112
CH240. ADA Sink Enclosure	25	TW720. Utility Basket	113
CH250. Plinth Base - Finished	22	TW722. Sharps Container Holder	114
CH255. Plinth Base - Unfinished	24	TW723. Vacuum Bottle Slide	115
CH300. Overhead Storage	27	TW724. Glove Box Holder	116
CH301. Awning Overhead Storage	31	TW725. 3 Clip Organizer	117
CH302. Open Shelving Overheads	33	TW726. Instrument Mounting Bracket	118
CH310. Sloped Top Overhead Storage	40	TW727. Sphygmomanometer Basket	119
CH311. Sloped Top Awning Overhead Storage	44	TW740. Mounting Clamp	120
CH312. Sloped Top Open Shelving Overheads	46	TW743. IV Pole	121
CH315. Sloped Top Panel	38	TW746. Chart Holder	122
CH316. Tower Sloped Top Panel	49	TW747. Utility Hook	123
CH320. Soffit	36	Y94015 Mbrace Wall-Mounted Technology	124
CH400. Wall-Mounted Door Towers	51	Y94105 Mbrace Extension Arm	125
CH405. To-The-Floor Door Towers	54		
CH410. Sloped Top Wall-Mounted Door Towers	57		
CH415. Sloped Top To-the-Floor Door Towers	60		
CH420. Wall-Mounted Shelf Towers	63		
CH421. 1" Shelf for Shelf Towers	66		
CH430. Straight Filler	67		
CH600. Corian Work Surface	69		
CH605. Corian Work Surface with Oval Sink	71		
CH606. Corian Work Surface with Rectangular Sink	73		
CH607. Corian Work Surface with ADA Sink	75		
CH610. Corian Work Surface with Work End	77		
CH615. Corian Work Surface with Work End and Oval Sink	78		
CH616. Corian Work Surface with Work End and Rectangular Sink	79		
CH618. Sidesplash	81		
CH620. HPL Work Surface	82		
CH630. HPL Work Surface with Work End	84		
CH646. Surface Wall Attachment Support	86		
CH650. HPL Backsplash	87		
CH655. End Panel	89		
CH660. Cantilever	91		
CH670. Backdrop Panel	93		
CH675. Floating Shelf	95		
CH680. Corian Peninsula	97		
CH685. HPL Peninsula	98		
CH690. Peninsula Leg	100		
CH700. Wall-Mounted Technology Cabinet	102		
CH710. Small Tech Cabinet Surface	104		



## 20-Day or Less/Assigned Lead-Time Order Information – Healthcare

### 20-Day or Less/Assigned Lead-Time Programs

20-day or less and assigned lead-time products are designed for established Herman Miller dealers with pre-approved credit.

Products are distributed from multiple manufacturing facilities across the United States. All products and options not designated by an Assigned Lead-Time icon **A** will ship in 20 business days or less after being acknowledged by Herman Miller. Products and options designated by an **A** are on the assigned lead-time program and will ship in 20 days, less than 20 days, or more than 20 days from order acknowledgement.

### Ordering Procedure

Please place orders through Order Manager. If this is not available to you, place orders through mail or fax. Verbal purchase orders will not be accepted.

Order Entry fax number: (616) 654 3085.

For more information, contact your Customer Care representative at:  
(866) 854 3048 EXT 3400

### Shipments and Delivery

Per Herman Miller Terms and Conditions.

### Changes and Cancellation

Per Herman Miller Terms and Conditions.





## Packaging

Packaging varies according to individual product. A surcharge may be added for special packaging requests. Contact Customer Care for specific information.

## Keyed-Alike Locks

All components with locks may be specified keyed alike.

Keyed-alike Mora™ System components will be shipped with lock chassis installed. Lock plugs will be shipped separately, tagged for product and location as specified. Installation of lock plugs will be on-site according to instructions provided. Herman Miller Inc., will not be responsible for lock plug installation.

To order keyed-alike locks for Mora™ System components, specify keyed alike. Then place a separate order for plugs and locks:

1. List plug part number and key number (232092-XXX); select a key number (or numbers) between 226 and 427, excluding numbers 408 and 412.
2. List quantity of locks per key number.
3. Indicate this is a no charge order.

Keyed-alike locks are field installed.

A master key can be used to open any lock on a Mora™ System component. To remove lock plugs from existing components, a removal key (#232228) or lock change tool (#234559) is required. Customers interested in ordering master keys, removal keys, or lock change tools should contact Customer Care with a written request.

For more information about our products and services or to see a list of dealers, please visit us at [HermanMiller.com](http://HermanMiller.com) or call (800) 851 1196.

© 2018 Herman Miller, Inc., Zeeland, Michigan

#### Distribution Rights

Working together since 1956, Herman Miller and Vitra are the authentic sources of designs by Charles and Ray Eames, Alexander Girard, and George Nelson. All the designs shown in this book are protected by law. Herman Miller has obtained all rights to make and sell these designs. Also, Herman Miller holds exclusive worldwide manufacturing and distribution rights for these products with the following exceptions:

Charles and Ray Eames, George Nelson, and Alexander Girard—Worldwide distribution rights for furniture in all areas except Europe and the Middle East. For those areas, please contact Vitra.

Isamu Noguchi—Worldwide distribution rights for the Noguchi Rudder Table. Distribution rights for the Noguchi Table in North America and Central America only. For all other areas, please contact Vitra.

Magis—Exclusive distribution rights in the US and Canada. For all other areas, please contact Magis.

Mattiazzi—Exclusive distribution rights in the US and Canada. For all other areas, please contact Mattiazzi.

® **HermanMiller**, ●, Action Office, Aeron, Aside, Avive, Canvas Office Landscape, Caper, Celle, Co/Struc, Eames, Embody, Equa 2, Ergon 3, Ethospace, Exclave, Fine-Tune, FlexFront, Formcoat, Ground Cloth, Herman Miller Healthcare, Layout Studio, Maharam, Meridian, Mirra, Passage, Pellicle, Perspectives, PostureFit, Resolve, Sayl, Setu, Thrive, Tu, Y-Tower, and Z-Axis are among the registered trademarks of Herman Miller, Inc., and its owned subsidiaries.

™ AireWeave, Bubbletack, Cellular Suspension, Compass, Connect, Cosm, DOT, Durawrap, Everywhere, Flex-Edge, Hopsak 2, Intent, Iota, Keyless Entry, Latitude, Lino, Lyris 2, Mora, Motia, Multiscrim, Nelson, Renew, Stackable, Swoop, TriFlex, Twist, and Verus are among the trademarks of Herman Miller, Inc., and its owned subsidiaries.

♾Chemsurf® is a registered trademark of Wilsonart International.

Corian® is a registered trademark of E.I. du Pont de Nemours and Company Corporation.

FLEXNET™ is a trademark of Milliken & Company.

Floor Saver Glide® is a registered trademark of Carpin Manufacturing, Inc.

Geiger® is a registered trademark of Geiger International.

Microsoft® and Natural® Keyboard are registered trademarks of Microsoft Corporation.

Place Textiles® is a registered trademark of Place Textiles.